

**Administrative arrangement between DG ENV and DG JRC on
“*Technical advice on the preparation of the common European
assessment methods to be used by the EU Member States for strategic
noise mapping after adoption as specified in the Directive
2002/49/EC*”
(Contract no. 070307/2008/511090)**

**Draft JRC Reference Report¹
on
Common NOise ASessment MethOdS in EU
(CNOSSOS-EU)**

**To be used by the EU Member States for strategic noise mapping
after adoption as specified in the Directive 2002/49/EC**

Version 2d, 28 May 2010

Disclaimer: The info contained in this report is confidential and should not be reproduced or disseminated without prior authorisation by the European Commission.

¹ **NOTE:** This version of the draft report reflects comments received by the reviewers till 20 May 2010. Comments received after 20 May 2010 will be taken on board in the next version of the draft report.

EXECUTIVE SUMMARY

The Institute for Health and Consumer Protection (IHCP) of the Directorate General Joint Research Centre (JRC) of the European Commission is supporting the Directorate General for the Environment (DG ENV) for the implementation of the European Noise Directive 2002/49/EC. In the context of the European Environmental Noise Directive 2002/49/EC (END), the European Commission decided to prepare Common Noise Assessment Methods (CNOSSOS-EU) for road, railway, aircraft and industrial noise in order to improve the reliability and the comparability of results across the EU Member States. This is foreseen in the Art. 6.2 of the END has been officially communicated and discussed during the Noise Regulatory Committee meeting which took place on 7th May 2008 in Brussels. The Joint Research Centre through the NOISE II administrative arrangement stipulated with DG ENV (*Contract no. 070307/2008/511090*) is in charge of preparing CNOSSOS-EU which after adoption by the EU Member States will be used in the future for producing noise maps and action plans.

The roadmap for the preparation of CNOSSOS-EU includes:

1. The exercise on equivalence of existing noise assessment methods in EU;
2. The definition of the target quality and input values requirements for European noise mapping;
3. The establishment of requirements and criteria for the screening, rating and pre-selection among existing assessment methods in EU, USA and Japan that best cover the needs and requirements of END;
4. The conceptualisation of a 'fit for purpose' framework which allows a two-level application of CNOSSOS-EU according to the objectives of the assessment;
5. The selection of the components of the common noise assessment methods through a series of Workshops, benchmarking/testing and other ad-hoc meetings with European noise experts;
6. The drafting of the CNOSSOS-EU methodology along with guidelines for its competent use in connection with data requirements and in line with the two-levels 'fit for purpose' framework;
7. The in-depth consultation, review and finalization of CNOSSOS-EU together with the EU Member States;
8. The preparation of the operational part of CNOSSOS-EU;
9. The long-term planning for assisting the EU MS to reliably implementing CNOSSOS-EU in the context of the future rounds of noise mapping in Europe.

As part of the aforementioned roadmap, JRC organised in liaison with DG ENV and EEA two milestones Workshops. The first Workshop on "*Noise mapping according to the 2002/49/EC: Target quality and input values requirements*" was organised in co-operation with DG ENV and EEA took place on 16-17 March 2009. In this event, wide consensus was achieved among 80 experts from 23 European Countries (*representatives of the MS, of Industry, National and Local authorities, Consultants, Research Institutions, EC Services and European Agencies*) on the framework to be followed for the preparation of the CNOSSOS-EU. The outcome of this Workshop is available through DG ENV's website (<http://ec.europa.eu/environment/noise/home.htm>).

The second Workshop on "*Selection of common noise assessment methods in EU*" took place on 8-9 September 2009 in Brussels. 30 noise experts participated in this event, including members from the EEA's EPoN group (Expert Panel on Noise) and model developers associated to the main existing noise methods in EU, USA and Japan for assessing road, railway, industrial and aircraft noise. During this event consensus was reached about the elements the common noise assessment methods in the EU should be composed of.

Due to the fact that for some of the components of the common noise assessment methods further investigations were deemed appropriate before these components could be adopted for CNOSSOS-EU, ad-hoc meetings and benchmarking/testing with various noise experts and stakeholders in the period November 2009-April 2010 were organised by JRC beyond the initial plans of the roadmap of CNOSSOS-EU. Four of these expert meetings were successfully organised:

- The Benchmarking/testing meeting on "*Road traffic noise source and propagation*", 17-18 November 2009, in Brussels
- The Ad hoc meeting on "*Railway traffic noise*", 7 December 2009, in Ispra
- The workshop on "*Aircraft noise prediction*", 19-20 January 2010, in Brussels
- The Ad-hoc meeting with software developers, 8-9 March 2010, in Ispra.

Reports for all of the aforementioned events have been drafted by JRC and reviewed by the experts involved so far in the CNOSSOS-EU roadmap. These reports are at their finalisation stage and will be uploaded to the DG ENV's CIRCA by 20 June 2010.

The present draft JRC Reference report is the outcome of the discussions held and consensus achieved during the aforementioned events among the European Commission (DG ENV, DG JRC) and the wide number of European noise experts involved so far in this exercise. It describes the CNOSSOS-EU methodological framework which can be used for strategic noise mapping purposes or for action planning.

The common noise assessment framework (CNOSSOS-EU) will allow for a coherent, transparent, optimised and reliable use for strategic noise mapping (first level of application, *mandatory*) and action planning (second level of application, *voluntary*) in relation to the data requirements, their quality and availability and last but not least, in terms of flexibility to adapt the national databases of input values, thus ensuring a smooth transition from existing national methods to the common methods.

At the first level of application, a simplified version of CNOSSOS-EU can be used with less input data requirements along with default data where appropriate; at the second level of application the more detailed state-of-the-art version of the CNOSSOS-EU with associated increased requirements of input data can be used on a voluntary basis for noise planning purposes. This would increase the consistency among the action plans adopted by the EU MS on the basis of the results of the noise mapping as stated in Art. 1 of the END and also would allow a better evaluation of the effectiveness of the action plans and the development of a basis for Community measures by the Commission to reduce noise emitted by the major noise sources (Art. 1.2 of the END). This would also allow the EU MS for concentrating more on the reliable implementation of a common tool (i.e., CNOSSOS-EU) and its further development, thus optimising their efforts instead of coping with different assessment noise methods used for different purposes which is a highly demanding task in terms of both, resources and time.

This draft JRC Reference report, suggests a set of simplifications, which have been, elaborated during the first phase of the drafting/reviewing of CNOSSOS-EU, which concern both, the source emission and propagation parts of the draft common noise methods. The aim is to further discussing this set of simplifications with the EU MS starting from the next Noise Regulatory Committee meeting to take place in Brussels on 11 June 2010, and achieve consensus on the final set of simplifications to be included in CNOSSOS-EU along with the associated level of accuracy to be accepted for strategic noise mapping purposes.

This draft JRC Reference report describes the methodological aspects of CNOSSOS-EU, however, this version does not yet include the input values and databases to be used for applying CNOSSOS-EU in practice. It should be underlined that, CNOSSOS-EU does not aim at covering the full range of existing national and regional peculiarities. However, in the Guidance for the competent use of CNOSSOS-EU to be prepared at a later stage, ways to introduce national or regional data will be described (e.g., particular road surface types or vehicle types used in some Member States).

Finally, this draft JRC Reference report is planned to be completed in the second half of 2010 along with the Guidance for the competence use of CNOSSOS-EU for the purpose of strategic noise mapping in EU after an in-depth consultation to be undertaken formally with the EU MS via the Noise Regulatory Committee meeting starting from 11 June 2010. It should stressed the fact that, the info contained in this report should be only considered as a solid background aimed at facilitating and streamlining the forthcoming discussions to be formally undertaken with the EU MS on CNOSSOS-EU. In the context of this formal consultation, it is envisaged to achieve consensus on the way forward for putting in place a robust methodological framework for common noise assessment methods in EU to be applied for reliably assessing exposure to environmental noise in Europe.

In conclusion, the European Commission is advancing the preparation of common noise assessment methods in EU (CNOSSOS-EU) with the ultimate scope to enhance the reliability and comparability of noise data in EU in the years to come. In this process, the European Commission and the European Environmental Agency progressively have been involving a wide number of European noise experts with the aim to prepare the ground for a more critical and in-depth discussions with the EU Member States (to be formally undertaken via the Noise Regulatory Committee meeting starting from 11 June 2010), on the basis of a robust framework of common noise assessment methods which takes into account the state of the art of scientific/technical/practical knowledge about assessment of environmental noise in Europe and also at global scale.

The European Commission, the European Environment Agency and the EU Member States aligned to the requirements of the END (art. 1.1) are intensifying their efforts for facing at best the big challenge and opportunity to:

- make available to the European citizens reliable info on the noise levels they are exposed to and the associated health implications;
- draw appropriate action plans for preventing and reducing exposure to harmful levels of noise.

Stylianos Kephelopoulos (*Co-ordinator of CNOSSOS-EU*)

Fabienne Anfosso-Lédée (*Technical manager of CNOSSOS-EU*)

TABLE OF CONTENTS

EXECUTIVE SUMMARY	3
TABLE OF CONTENTS	7
LIST OF CONTRIBUTORS.....	11
CHAPTER I. INTRODUCTION.....	17
I.1. The roadmap for the preparation of CNOSSOS-EU	17
I.1.1 Step 1: Exercise on equivalence of existing noise assessment methods in EU	17
I.1.2 Step 2: Definition of the target quality and input values requirements for European noise mapping	17
I.1.3 Step 3: A ‘fit for purpose’ framework for a two-level application of CNOSSOS-EU according to the objectives of the assessment.....	19
I.1.4 Step 4: Requirements and criteria for the screening, rating and pre-selection among existing noise assessment methods.....	21
I.1.5 Step 5: Selection of the components the common noise assessment methods	24
I.1.6 Step 6: Drafting of the CNOSSOS-EU methodology along with guidelines for its competence use.....	26
I.1.7 Step 7: Consultation, review and finalization of CNOSSOS-EU together with the EU Members States	26
I.1.8 Step 8: Preparation of the operational part of CNOSSOS-EU.....	26
I.1.9 Step 9: Long-term planning for assisting the EU MS to reliably implementing CNOSSOS-EU in the context of the future rounds of noise mapping in Europe.....	27
I.2. Background and objectives of this report.....	27
I.3. Definitions and symbols.....	29
I.3.1. General concepts	29
I.3.2. One-third-octave bands	34
I.3.3. Indicators.....	35
CHAPTER II. ROAD NOISE SOURCE EMISSION.....	37
II.1. Source description.....	37
II.1.1. Classification of vehicles	37
II.1.2. Number and position of equivalent sound sources	38
II.2. Sound power emission	40
II.2.1. General considerations.....	40
II.2.2. Reference conditions.....	42
II.2.3. Rolling noise	42
II.2.4. Propulsion noise.....	44
II.2.5. Effect of the type of road surface.....	47
II.2.6. Source directivity	49
II.3. Additional effects	50
II.3.1. General considerations for regional corrections	50
II.3.2. Correction for regional road conditions and environment	51
II.3.3. Correction for fleet regional specificities.....	52
II.3.4. Correction for structural radiation (bridges and viaducts)	54

II.3.5.	Correction for tunnel openings	55
	References	55
	APPENDIX II-A - Table of coefficients for sound power emission of road vehicles	57
	APPENDIX II-B - Correction coefficients for air temperature effect on rolling noise.....	59
	APPENDIX II-C - Examples of correction coefficients for road surface effect on rolling noise	61
	APPENDIX II-D - Coefficients for studded tyres effect on rolling noise emission - Light motor vehicles (Cat.1).....	65
	CHAPTER III. RAILWAY NOISE SOURCE EMISSION	67
III.1.	Source description	67
III.1.1.	Classification of vehicles	67
III.1.2.	Classification of tracks and support structure	72
III.1.3.	Number and position of the equivalent sound sources.....	74
III.2.	Sound power emission	75
III.2.1.	General equations.....	75
III.2.2.	Rolling noise	78
III.2.3.	Impact noise (crossings, switches and junctions)	81
III.2.4.	Squeal.....	82
III.2.5.	Braking noise	82
III.2.6.	Traction noise.....	83
III.2.7.	Aerodynamic noise	84
III.2.8.	Source directivity	85
III.3.	Additional effects	86
III.3.1.	Correction for structural radiation (bridges and viaducts)	86
III.3.2.	Correction for other railway related noise sources	87
	References	87
	CHAPTER IV. INDUSTRIAL NOISE SOURCE EMISSION	91
IV.1.	Source description	91
IV.1.1.	Classification of source types (point, line, area).....	91
IV.1.2.	Number and position of equivalent sound sources	91
IV.2.	Sound power emission	92
IV.2.1.	General.....	92
IV.2.2.	Source directivity	93
IV.2.3.	Measurements	93
IV.2.4.	Use of pre-defined database.....	94
	References	95
	CHAPTER V. SOUND PROPAGATION.....	97
V.1.	Set up of the model.....	97
V.1.1.	Geometrical considerations.....	97
V.1.2.	Sound propagation model	99

V.2.	Excess attenuation	101
V.2.1.	Diffraction, ground reflection and scattering	101
V.2.2.	Recursive process.....	102
V.3.	Diffraction attenuation	103
V.4.	Ground attenuation	104
V.4.1.	Concave ground model	104
V.4.2.	Fresnel weighting.....	109
V.4.3.	Transition model	112
V.5.	Atmospheric refraction.....	115
V.5.1.	Sound speed profile.....	115
V.5.2.	Curved ground analogy	115
V.6.	Scattering by atmospheric turbulence	116
	References	116
	APPENDIX V-A - Linearization of logarithmic sound speed profiles	119
	CHAPTER VI. AIRCRAFT NOISE PREDICTION	121
VI.1.	The component of CNOSSOS-EU for aircraft noise	121
VI.2.	Recommendations	121
	CHAPTER VII. GUIDANCE ON THE COMPETENT USE OF CNOSSOS-EU	128
VII.1.	Scope, aims and objectives of the guidance.....	128
	References	130

LIST OF CONTRIBUTORS

This draft JRC Reference Report is the result of a collective work with the contribution of many noise experts from several European countries. In particular, the following noise experts have participated so far to the **co-ordination** and 1st cycle of **drafting/reviewing** of CNOSSOS-EU.

Co-ordination

S. Kephelopoulos (JRC-IHCP) (*overall co-ordinator*)
F. Anfosso-Lédée (JRC-IHCP) (*technical manager*)

Chapter I - Introduction

S. Kephelopoulos (JRC-IHCP) (*main drafter*)
F. Anfosso-Lédée (JRC-IHCP)

Chapter II - Road noise source

F. Anfosso-Lédée (JRC-IHCP) (*main drafter*)
W. Bartolomaeus (BAST, Germany)
H. van Leeuwen (DGMR, The Netherlands)
R. Nota (DVS, The Netherlands)
H. Jonasson (Consultant, Sweden)
J. Lelong (INRETS, France)
B. Peeters (M+P, The Netherlands)
G. van Blokland (M+P, The Netherlands)
P. de Vos (DHV, The Netherlands)

Chapter III - Railway noise source

M. Paviotti (noise consultant, Italy) (*main drafter*)
M. Beuving (DeltaRail, The Netherlands)
M. Dittrich (TNO, The Netherlands)
R. Jones (Consultant, United Kingdom)
U. Moehler (Moehler & Partners, Germany)
F. Poisson (SNCF, France)

Chapter IV - Industrial noise source

M. Paviotti (Noise consultant, Italy) (*main drafter*)
R. Witte (DGMR, The Netherlands)

Chapter V - Noise propagation

F. Anfosso-Lédée (JRC-IHCP) (*main drafter*)
G. Dutilleux (CETE Est, France)
B. Plovsing (Delta, Denmark)
D. van Maercke (CSTB, France)
E. Salomons (TNO, The Netherlands)

Chapter VI - Aircraft Noise prediction²

D. Rhodes (Civil Aviation Authority, United Kingdom) (*main drafter*)
L. Cavadini (EUROCONTROL, Int)
N. Van Oosten (Anotec Consulting SL, Spain)
U. Iserman (DLR, Germany)

Chapter VII - Guidance on the competent use of CNOSSOS-EU

S. Shilton (Acustika Ltd., United Kingdom) (*main drafter*)
N. Jones (Extrium, United Kingdom)
D. van Maercke (CSTB, France)
T. Werst (EBA, Germany)
P. de Vos (DHV, The Netherlands)
M. Paviotti (Noise consultant, Italy)
F. Anfosso-Lédée (JRC-IHCP)
S. Kephelopoulos (JRC-IHCP)

Furthermore, a wide number of noise experts have been involved in the discussions during and after the workshops and the ad-hoc meetings organised in the context of the roadmap to prepare CNOSSOS-EU, and contributed to the recommendations that were made regarding the current stage of development of CNOSSOS-EU.

◆ The Benchmark/Testing ad-hoc meeting on “Road traffic noise source and propagation”, 17-18 November 2009, Brussels

W. Bartolomaeus (BAST, Germany)
M. Cerchiai (ARPAT Toscana, Italy)
J. Defrance (CSTB, France)
G. Dutilleux (CETE Est, France)
E. Le Duc (SETRA, France)
J. Lelong (INRETS, France)
G. Licitra (ARPAT Toscana, Italy)
R. Nota (DVS, The Netherlands)
M. Paviotti (Noise consultant, Italy)
B. Peeters (M+P, The Netherlands)
B. Plovsing (Delta, Denmark)
D. van Maercke (CSTB, France)
H. Jonasson (Noise consultant, Sweden) (apologies)
L. Schade (UBA, Germany) (apologies)

S. Kephelopoulos (JRC-IHCP)
F. Anfosso-Lédée (JRC-IHCP)
G. Balazs (DG ENV)
C. Nugent (EEA)

² Chapter VI at this stage includes only the draft recommendations made during the Workshop on “Aircraft noise prediction” took place on 19-20 January 2010 in Brussels. The drafting of this chapter will be done after the minutes of the aforementioned Workshop will be finalized.

◆ **The ad hoc meeting on “Railway traffic noise”, 7 December 2009, Ispra**

M. Dittrich (TNO, The Netherlands)
H. Jonasson (Noise consultant, Sweden)
R. Jones (Noise consultant, United Kingdom)
F. Letourneaux (SNCF, France)
U. Moehler (Moehler & Partners, Germany)
M. Paviotti (Noise consultant, Italy)
T. Werst (EBA, Germany)
I Aspuru (LABLEIN, Spain) (apologies)
M. Beuving (DELTARAIL, The Netherlands) (apologies)
R. Ortner (Umweltbundesamt, Austria) (apologies)

S. Kephelopoulos (JRC-IHCP)
F. Anfosso-Lédée (JRC-IHCP)

◆ **The workshop on “Aircraft noise prediction”, 19-20 January 2010, Brussels**

D. Bergmans (NLR, The Netherlands)
L. Cavadini (EUROCONTROL, Int)
C. Damar (ACI EUROPE, Belgium)
P. de Vos (DHV, The Netherlands)
L. Ehnborn (Swedish Transport Agency, Sweden)
I. Granoien (SINTEF ICT, Norway)
M. Hankenen (LFV Group, Sweden)
U. Isermann (DLR, Germany)
A. Kruger Dokter (NLR, The Netherlands)
R. Kucharski (Institute of Environmental Protection, Poland)
T. Leskelä (Ilmailulaitos Finavia, Finland)
K. H. Liasjø (Oslo Lufthavn AS, Norway)
A. Malige (DGAC/STAC, France)
M. Paviotti (Consultant, Italy)
M. Portier (To70 Consulting company, The Netherlands)
D. Rhodes (Civil Aviation Authority, United Kingdom)
S. Turner (Bureau Veritas (for Defra), United Kingdom)
N. Van Oosten (Anotec Consulting SL, Spain)
M. Viinikainen substituted by T. Leskelä (Finavia Corporation, Finland)
(apologies)
R. Girvin (FAA, USA) (apologies)

S. Kephelopoulos (JRC-IHCP)
F. Anfosso-Lédée (JRC-IHCP)
G. Balazs (DG ENV)
C. Nugent *(apologies)*
K. de Vos (DG TREN) *(present only the 1st day)*
H. Vu Duc (DG TREN) *(present only the 1st day)*
S. Arrrowsmith (EASA)
W. Franken (EASA)

◆ **The ad-hoc meeting with Software Developers, 8-9 March 2010, Ispra**

K.G. Krapf (Wölfel Meßsysteme Software GmbH+Co, Germany)
W. Probst (Datakustik GmbH, Germany)
J. Schaal (Braunstein + Berndt GmbH, Germany)
H. Stapelfeldt (Stapelfeldt Ingenieurgesellschaft mbH, Germany)

H. van Leeuwen (DGMR consultants, The Netherlands)
D. van Maercke (CSTB, France)
D. Zollitsch (Braunstein + Berndt GmbH, Germany)
D. Manvell (Brüel & Kjaer, Denmark) (apologies)
C. Popp (Lärmkontor GmbH, Germany) (apologies)

N. Jones (Extrium, United Kingdom)
U. Moehler (Moehler + Partner, Germany)
M. Paviotti (Noise consultant, Italy)
S. Shilton (Acustica Ltd, United Kingdom)
T. Werst (EBA, Germany)
P. de Vos (DHV, The Netherlands) (apologies)

S. Kephelopoulos (JRC-IHCP)
F. Anfosso-Lédée (JRC-IHCP)
J. Lekaviciute (JRC-IHCP)
B. Gergely (DG ENV) (*apologies*)

◆ **Workshop on the "Selection of common noise assessment methods in EU", 8-9th September 2009, Brussels**

I. Aspuru(Labein, Spain)
A. Bäckman (Expert Panel on Noise, Sweden)
W. Bartolomaeus (BAST, Germany)
J.L. Bento Coelho (CAPS - Instituto Superior Técnico, Portugal)
N. Blanes Guardia (ETCLUSI, Spain)
A. Bloomfield (Consultant, United Kingdom)
L. Cavadini (EUROCONTROL, France)
P. de Vos (DHV bv, The Netherlands)
G. Dutilleux (CETE de l'est, France)
I. Granoien (SINTEF ICT, Norway)
J. Hinton (Birmingham City Council, United Kingdom)
H. Jonasson (SP Technical Research Institute, Sweden)
N. Jones (Extrium, United Kingdom)
R. Jones (DeltaRail, United Kingdom)
E. Le-Duc (SETRA, France)
G. Licitra (ARPAT, Italy)
A. Malige (DGAC/STAC, France)
U. Moehler (Moehler + Partner, Germany)
V. O' Malley (National Roads Authority, Ireland)
M. Paviotti (Noise consultant, Italy)
B. Plovsing (DELTA, Denmark)
S. Rasmussen (COWI Acoustics and Noise, Denmark)
L. Schade (Umweltbundesamt, Germany)
S. Shilton (Acustica Ltd., United Kingdom)
S. Turner (Bureau Veritas (for Defra), United Kingdom)
D. van Maercke (CSTB, France)
N. van Oosten (Anotec Consulting SL, Spain)
T. Werst (Eisenbahn Bundesamt, Germany)
R. Witte (DGMR, The Netherlands)

S. Kephelopoulos (JRC-IHCP)

F. Anfosso-Lédée (JRC-IHCP)
B. Gergely (DG ENV)
C. Nugent (EEA)

◆ **Workshop on "Target Quality and Input Values Requirements for Noise Mapping", 17-18th March 2009, Ispra**

W. Alberts (Ministry of Transport, The Netherlands)
I. Aspuru (Labein Tecnalia, Spain)
E. Aune (Health and Welfare Agency, Norway)
A. Bäckman (Expert Panel on Noise, Sweden)
J. L. Bento Coelho (CAPS - Instituto Superior Técnico, Portugal)
A. Bisceglie (Università Milano Bicocca, Italy)
P. E. Bite (Vibrocomp Ltd., Hungary)
N. Blanes Guardia (ETCLUSI, Spain)
J. Borst (TNO, The Netherlands)
Y. Bosworth (Dept. for Environment, Food and Rural Affairs, United Kingdom)
G. Bruno (Regione Lombardia, Italy)
M. Burdett (EXTRIUM, United Kingdom)
F. Chonianaki (Noise consultant, Greece)
J. L. Cueto (University of Cadiz, Spain)
P. de Vos (DHV bv, The Netherlands)
M. Dittrich (TNO, The Netherlands)
I. Dombi ((Vibrocomp Ltd, Hungary)
G. Dutilleux (CETE de l'est, LRPC de Strasbourg, France)
H. Evans (Welsh Assembly Government, United Kingdom)
J. Fons Esteve (ETC LUSI, Spain)
M. Galabova Kostova (Ministry of Environment and Water, Bulgaria)
T. Gjestland (SINTEF ICT, Norway)
A. Globevnik (A.Projekt d.o.o., Slovenja)
I. Granoien (SINTEF ICT, Norway)
R. Hernandez (University of Cadiz, Spain)
J. Hinton (Birmingham City Council, United Kingdom)
J. Hlavacek (Railway Research Institute, Czech Republic)
K. Ingold (Federal Office for Environment FOEN, Switzerland)
A.-C. Ionescu (INCDT COMOTI, Romania)
S.-E. Ionescu (INCDT COMOTI, Romania)
N. Jones (Extrium, United Kingdom)
R. Jones (DeltaRail, United Kingdom)
P. Junek (Ministry of Health, Czech Republic)
R. Kucharski (Institute of Environmental Protection, Poland)
L. Kuhelj (Environment Agency, Slovenia)
E. Le Duc (SETRA Ministry, France)
G. Licitra (ARPAT, Italy)
L. Liikonen (Uusima Regional Environmental Centre, Finland)
J. Lindmaier (Federal Environmental Agency, Germany)
A. Määttä (Sito Oy, Finland)
D. Manvell (Brüel & Kjaer, Denmark)
B. Mc Kell (Faber Maunsell, United Kingdom)
J. Michalik (Ministry of Health, Czech Republic)
L. Mihalcik (RUVZ – Regional Health Authority, Slovak Republic)
K. Nolan (Environmental Protection Agency, Ireland)

V. O' Malley (National Roads Authority, Ireland)
S.-L. Paikkala (Ministry of the Environment, Finland)
D. Palmer (Faber Maunsell, United Kingdom)
E. Poikolainen (Finnish Rail Administration, Finland)
W. Probst (DataKustik GmbH, Germany)
T. Przybilla (Landesamt für Natur, Umwelt und Verbraucherschutz, Germany)
E. Quaia (Università degli Studi di Milano Bicocca, Italy)
S. Radaelli (Università degli Studi di Milano Bicocca, Italy)
S. Routama (Finavia, Finland)
E. Salomons (TNO, The Netherlands)
L. Schade (Umweltbundesamt, Germany)
S. Shilton (Acustica Ltd., United Kingdom)
R. Silvaggio (APAT, Italy)
A. Stenman (Tyrens Akustik AB, Sweden)
A. Stimac (DARH 2 Acoustics & Civil Eng. Ltd., Croatia)
S. Turner (Bureau Veritas (for Defra), United Kingdom)
V. Uscila (State Environmental Health Centre, Lithuania)
X. Valero Gonzalez (Ramon Llull University, Spain)
A.-J. van Beek (Netherlands Environmental Assessment Agency, The Netherlands)
M. van Den Berg (Ministry VROM, The Netherlands)
H. van Leeuwen (DGMR, The Netherlands)
D. van Maercke (CSTB, France)
N. van Oosten (Anotec Consulting SL, Spain)
F. van Ryn (Netherlands Environmental Assessment Agency, The Netherlands)
A. Vasileiadis (Freelancer, Acoustics & Noise Consultant, Greece)
M. Weber (DCMR Environmental Protection Agency, The Netherlands)
T. Werst (Eisenbahn Bundesamt, Germany)
E. Wetzlar (Wölfel Messsysteme, Germany)
F.-C. Zacharias (TLUG, Germany)

S. Kephelopoulos (JRC-IHCP)
M. Paviotti (JRC-IHCP)
G. Balazs (DG ENV)
C. Nugent (EEA)
W. Schneider (DG ENTR)
S. Arrowsmith (EASA)
G. Gardiol (European Railway Agency)

CHAPTER I. INTRODUCTION

I.1. The roadmap for the preparation of CNOSSOS-EU

I.1.1 Step 1: Exercise on equivalence of existing noise assessment methods in EU

An exercise on equivalence of existing noise methods used by the EU Member States (EU MS) against the interim methods was undertaken in 2008 by DG ENV assisted by the European Commission's Joint Research Centre. The outcome of this exercise revealed that concerning the compliance of the EU MS to Art. 6 of the Environmental Noise Directive (END):

- ❖ 7 EU MS were assessed to be compliant with Art. 6 of the END for all noise assessment methods used.
- ❖ 5 EU MS were assessed to be non-compliant with Art. 6 of the END for at least one noise assessment method.
- ❖ For 15 EU MS it was impossible to determine their compliance with Art. 6 of the END for at least one noise assessment method because they did not provide enough information to allow assessing whether their national methods are equivalent to the interim ones.

It should be underlined that, those EU MS assessed to be compliant with Art. 6 of the END were those that have declared using the Interim methods (Art. 6.1, Annex II). However, it is widely recognised that these methods do not represent any more the state of the art in noise assessment and they have been superseded by other recently updated and/or newly developed methods.

The above outcome, further stressed the necessity and also the importance of preparing common noise assessment methods in EU to be made available to the EU MS for the forthcoming rounds of noise mapping in Europe. This task is actually carried out by the Joint Research Centre who designed together with DG ENV and EEA a roadmap for putting in place the Common NOise aSSessment methOdS (CNOSSOS-EU) for road, railway, aircraft and industrial noise in the period 2009-2011 in close liaison with the EU MS.

I.1.2 Step 2: Definition of the target quality and input values requirements for European noise mapping

Step 2 of the roadmap for the preparation of CNOSSOS-EU has been highly motivated by the suggestions received from representatives and experts of the EU Member States in the context of the Noise Regulatory Committee meeting in May 2008 and also during other recent technical and scientific forums on environmental noise. These suggestions reveal the concerns of the EU MS and other noise experts about the quality, availability and comparability of input values and techniques used in the noise mapping.

A workshop on “*The target quality and input values requirements for European noise mapping*” was then organised on 17-18 March 2009 in Ispra by the Joint Research Centre in cooperation with DG ENV and the European Environment Agency.

This workshop addressed public authorities dealing with environmental noise in the EU MS, private noise consultants and software developers already involved in the 1st round of European

noise mapping who were invited to contribute to the development of requirements on the input values and their associated quality in view of the next rounds of European noise mapping.

The importance the aforementioned milestone event received among the various stakeholders was reflected in the broad participation that included almost 80 people from 20 European Countries representing: European Commission and Agencies (7), National / Local Authorities (32), Software Developers (3), Research Institutions / Universities (15), Private Noise Consultants (21), Industry (1). The European Commission services participated were: DG ENV, DG ENTR, JRC and the three European agencies were the European Environment Agency (EEA), the European Railway Agency (ERA) and the European Aviation Safety Agency (EASA).

Based on the presentations made and discussions held during the Workshop (in both, the plenary and break-out sessions), general conclusions and recommendations for future actions were drafted for which consensus of the Workshop's participants was achieved. These were mainly concerned with some fundamental improvements that were retained as necessary to be included in the second round of noise mapping to ensure "**precision, accuracy and credibility**" of the noise maps and of the population exposure estimations. These are briefly summarised below:

- **Reliable and comparable results** at EU level should be obtained through establishing common assessment methods.
- The reliability and comparability of results should be maximised through setting up a **guidance on the competent use of noise assessment methods** accompanied by a **quality system** in relation to:
 - a) the relevant quality and quantity of input data;
 - b) the use, extraction, and management of input databases;
 - c) the calculation settings in software;
 - d) the software use and the modelling techniques used.
- **Reporting mechanism** to report noise maps and population exposure should be made mandatory.
- The quality system to introduce regarding input data collection and use should specifically comprise the following elements:
 - Specifications for **GIS input/output** data and data collection
 - Specification on **degree of detail** of the input data tailored for different noise mapping needs, e.g., strategic (global) noise mapping versus detailed (local) noise mapping for action planning
 - A standard scheme to be followed for the **collection** of information on the datasets used and **data processing** procedures used
 - Specific conditions related to the definition and usage of "**default**" input data
 - A fixed methodology to **attribute population exposure** to noise levels
- An **EU calculation code** (both, for strategic and detailed noise mapping) should be established and updated centrally and periodically by the EC in collaboration with software developers.

- There is a need to constitute an *open and public database* of global input values to be used together with CNOSSOS-EU, that is centrally *managed and* periodically *updated by the EC* on the basis of contributions from the EU MS
- The same degree of “*comparable*” *results for all four calculation methods* (i.e., road, railway, industrial and aircraft) should be ensured.

An integration of the noise GIS data into the set-ups under the *INSPIRE* directive (i.e., Annexes I to III of INSPIRE) was also envisaged.

For the detailed reporting on the outcome of the Workshop’s plenary and break-out sessions the reader is advised to consult the following web address: <http://ec.europa.eu/environment/noise/>.

I.1.3 Step 3: A ‘fit for purpose’ framework for a two-level application of CNOSSOS-EU according to the objectives of the assessment

It is well recognised that there may be different requirements on a noise assessment method, depending upon the purpose of the assessment. Two main purposes pertaining to the conceptualisation of a ‘fit for purpose’ framework which allows a two-level application of CNOSSOS-EU according to the objectives of the assessment were identified and agreed upon in the Workshop organised in step 2 and further elaborated in step 3 of the roadmap related to CNOSSOS-EU.

The ‘fit for purpose’ framework, elaborated in the period May-June 2009 and agreed among 25 European noise experts including the members of the EEA’s Expert Panel on Noise, is briefly outlined below:

A **first purpose** relates to the ability to perform an overall impact assessment of sound exposure in large urban areas, and through a common approach to identify hot spots and quantify overall numbers of people exposed and associated health effects, with reasonable approximations. In this case, there is no need to seek for highly accurate results for each specific assessment position and a reasonably simplified assessment approach might be sufficient (i.e, the same method is used with simplified set of input values). This is mainly needed for fulfilling the obligations of **strategic noise mapping required by the END**. The use of the common noise assessment methods for this first purpose includes:

1. Support to the EU level policy:
 - a) Strategic noise mapping results need to provide the overall health impact assessment with exposure data across the majority of the population thought to be exposed to environmental noise as this is considered to pose a potential long-term risk to health and well-being.

A **second purpose** relates to the precise determination of the noise levels to which people are exposed, eventually within those areas where deeper understanding of the problem is required to identify, implement and evaluate the effectiveness of action plans either at local level, at MS level or at EU level. Detailed results can be obtained by appropriately employing the common assessment methods with detailed input values. Examples of possible use of the assessment methods for this second purpose are:

1. Support to the EU level policy:

- a) Noise mapping results need to provide supporting information to provide a basis for source noise legislation (including tyre noise, vehicle pass by noise, road surfaces descriptions, rail vehicle interoperability, aircraft fleet restrictions etc).
- b) The method needs to be able to support these policy areas by being able to use such data as inputs, either to reflect the current situation, or to run "what if" scenarios to help formulate policy alternatives and assess their impact. This will enable the EU MS to undertake an assessment of the impact of policy alternatives, thus formulate appropriate proposals to the European Council.

2. Support MS level policy aspects:

- a) vehicle restrictions
- b) tyre restrictions or special types
- c) traffic calming
- d) promotion of electric / hybrid vehicles
- e) promotion of vehicle fleet change through financial incentives to scrap older cars, older trains, older aircrafts
- f) noise-differentiated track and airport access charging
- g) action plan policies etc

3. Local Action Plan policy aspects:

- a) local actions such as those within the ‘Silence’ handbook
- b) road surface changes
- c) different types of barriers (in general, e.g. berms, walls, embankments etc.), their materials, shapes, sizes, acoustical performance or other functionalities (e.g.: absorbent/reflective, curved, tilted, complex overhanging, with photovoltaic devices and with top devices).
- d) rail grinding, rail vehicle brake changes, tuned rail absorbers, mitigation of rail curve squeal
- e) transferring night time rail and aircraft movements to the day
- f) switch to different type of cars and trains (e.g.: electric/hybrid cars, diesel to electric locomotives)
- g) low emission zones
- j) calculations for quiet areas in open countryside

The method should reflect - as much as possible - the effects of all such action plans in future strategic noise maps. Not showing the effect of some action plans might discourage the MS to undertake such actions and/or to prefer "well known" types of actions (taken into account by the prediction methods) compared to more innovative actions (whose effects are not well taken into account by the prediction methods).

For both purposes, it should be possible to use the common noise assessment method with reasonable effort. Consequently, requirements on input data might be kept commensurate with the level of resolution and accuracy relevant to each purpose of the assessment. These needs are best described by a “**fit for purpose**” approach, and this approach is fully considered during the preparation of CNOSSOS-EU.

It was acknowledged that many of the existing national methods do not provide support for many of the above aspects, and thus would not actively support the assessment of policy options or action plan cost benefit analysis. It was considered that the applicability of

CNOSSOS-EU to use in action planning and policy development was probably a key aspect going forward, and is probably an emerging requirement compared to traditionally-designed national methods which may have been designed primarily for use in Environmental Impact Assessments, or testing against limit values.

However, it should be stressed the fact that, unless will be an agreement with EU MS in the context of the review of the END, for the time being, CNOSSOS-EU will be used for strategic noise mapping as required by the END *on a mandatory basis* and for action planning *only on a voluntary basis*.

I.1.4 Step 4: Requirements and criteria for the screening, rating and pre-selection among existing noise assessment methods

In the period June-July 2009, the Joint Research Centre assisted by 25 European noise experts and the members of the EEA's Expert Panel on Noise, established a list of requirements and criteria for the screening, rating and pre-selection among existing noise assessment methods in EU, USA and Japan that best cover the needs and requirements of the END. These requirements and criteria are outlined below:

GENERAL REQUIREMENT FOR A "FIT FOR PURPOSE" METHOD

Based on the outcome of steps 2 and 3, it was deduced that the need for an appropriate noise assessment method in an EU context could be best fulfilled by a two level of input data method that can be used either *using a simplified set of inputs, to fulfil the aforementioned "first purpose"*, or *with a more detailed set of inputs to fulfil the "second purpose"*.

It should be noted that any detailed methodology can in principle *be reduced to a simpler to use methodology* by applying default values to most of its parameters and by performing calculations under a reduced number of source and propagation conditions. Also, methods using octave band data *can be simplified to be used with A-weighted levels* by means of the use of corresponding equivalent default spectra. Finally, a detailed method could allow fine-tuning of the input values and parameters to *match the specific national source and propagation description of a pre-existing national method*.

On the basis of the aforementioned considerations, it was concluded that, the ideal method would then be a complex method which supports reduction to a simplified version, by fixing a set of input values (e.g. by using default values) and appropriate default assumptions for those of the input values not commonly available. For example, the method, requiring octave band spectra, can be simplified to be used with dB-A weighted value by proposing source-specific default spectra to convert these dB-A weighted values to the required input data for the method.

SPECIFIC REQUIREMENTS FOR THE COMMON NOISE ASSESSMENT METHODS (FULFILL THE END AND TO BE APPLICABLE THROUGHOUT THE EU MEMBER STATES)

To fulfil the END requirements (Annex I in particular), the assessment method should be capable to:

- give L_{den} and L_{night} values;
- calculate each source type separately;

- give results at **4 m** height **0.1 m** in front of the façade;
- consider the **average meteorological year**;
- neglect the **effect of the façade reflection** of that façade corresponding to the assessment point;
- capable of calculating values for quiet areas

Moreover, given also the need to ensure not only calculations near to the source, but also far from it, it would be preferable to have:

- calculations in **octave bands** (Lots of data on sources is only available in whole octaves 63 to 8000 Hz)

Some more features are considered to be part of the set of standard requirements related to the common noise assessment methods:

- **geometrical** divergence;
- **atmospheric** absorption;
- terrain features (**height**, ground **impedance**);
- **reflections** and **diffractions** on and around obstacles (including buildings, screens and noise barriers).
- the **segmentation technique** (decomposition of large sources in smaller entities, based on acoustical criteria) should be specified for all sources;

To ensure an applicability of the methods in the different specific situations encountered in the EU MS, some more conditions should **possibly** be met, namely considering the following details:

For noise propagation:

- different **combinations of propagation conditions** are allowed;
- each propagation condition can be defined starting from **meteorological parameters** that influence the sound ray profile and air attenuation (temperature, humidity, air density gradients, wind speed and temperature gradients and wind direction).

For noise source definition:

ROAD TRAFFIC NOISE:

- at least four vehicle categories (motorbikes, passenger cars, light and heavy trucks);
- road surface types;
- differences in fleet composition between MS;
- different tyre types, engine noise/rolling noise;
- acceleration/deceleration, gradients;
- acoustical effect of specific points (tunnels, viaducts,...);
- effect of speed lower than 50 km/h.

RAILWAY TRAFFIC NOISE:

- different wheel and rail roughness;
- different track/support structure types and different vehicle types;
- different engine noise;
- different air management/cooling system noise;
- different aerodynamic noise;

- acoustical effect of specific points (e.g., squeal, bridges, etc);
- easiness to obtain "national" emission data (i.e., to adjust the proposed default values based on measurements on specific rolling stock);

INDUSTRIAL NOISE:

- lateral diffraction around obstacles;
- specific modelling of low frequencies;

AIRCRAFT NOISE:

- different aircraft performance as a function of aircraft type, engine type and take-off weight (TOW);
- air parameters (temperature, pressure and wind speed and direction);
- different noise abatement procedures for both take off and approaches;

In addition, it is desirable to consider methods whose reliability is proven and whose uncertainties related to the results are known, therefore:

- **validity of the scientific background** of the parts that compose a method should be considered;
- **validation** of the results obtained by the application of the method complements the requirement on scientific background;
- **procedure to assess the uncertainty related to the method.**

For a method to be considered in the process of preparing common noise assessment methods, also it should be ensured that:

- the method is available **free of any royalties and IPR issues**;
- a clear description should accompany the methods; this will help an **easy implementation of the methods** into software and its usage by the end users;
- reasonable calculation times.

Concerning the easiness of use of the method, two more relevant requirements were considered:

- **availability** of the set of **parameters** and of the **input values**, at least default ones, to be used with the method;
- **frequency of update** of the parameters and the input values;
- **ability to adapt to local conditions** (such as different vehicle fleets, different railway tracks and road surfaces).

Preference was given to solutions suggesting:

- **common parts between the road, the railway, the industrial and the aircraft noise calculation methods.**
- **clear separation of noise emission and noise propagation** (this will result in methods that are more easily adapted to new type of sources and/or in case of important technological changes at the source level).

These requirements were also based on the discussions held during the March 2009 workshop in Ispra, where among the consensus reached on the various topics discussed, it was also to have as much uniformity between the four methods as possible, given that the physics of noise

generation and propagation remains the same regardless of the source, and comparable results is an asset.

CRITERIA FOR THE SELECTION OF THE FUTURE EUROPEAN COMMON NOISE ASSESSMENT METHODS

Existing noise assessment methods fulfil several of the aforementioned requirements, therefore it is expected that within the process of selection of the common methods a number of viable options may be identified. Some of the outlined requirements have been considered as '*essential*', meaning that the non-fulfilment of such requirement will result in considering such a method as inappropriate to meet END requirements and basic environmental noise assessment standards. The rest of the requirements not being essential are indicated as '*recommendable*' to be part of the common methods. This is to consider those requirements that are nowadays and in the next future welcome, mostly for properly evaluating noise reduction measures.

The procedure for the selection of the common methods consequently has been:

- 1. To pre-select those methods that fulfil the essential criteria (mainly the requirements of the END);**
- 2. To identify the best ones fulfilling most or all of the recommendable requirements;**

As an option was kept to combine parts of the existing methods provided that this is considered appropriate to obtain the 'best in class', conforming also to the necessity to develop a 'fit for purpose' method.

I.1.5 Step 5: Selection of the components the common noise assessment methods

An evaluation exercise on existing noise assessment methods in EU, USA and Japan was conducted by the Joint Research Centre in the period July-August 2008 on the basis of:

- ❖ The requirements and the criteria previously established in step 4;
- ❖ Through a systematic literature review in peer-reviewed journals and articles in international conferences;
- ❖ By contacting the method developers (or the national offices responsible for the methods) to get info about potential updates of the methods and their validation status. The list of methods considered in the evaluation exercise is the following:

The noise assessment methods which have been evaluated are presented in Table 1.

Table 1 – Noise assessment methods evaluated for the selection of the components of the CNOSSOS-EU

Road traffic noise method	Country	Industrial noise method	Country
ASJ RTN 2008	JP	HARMONOISE/IMAGINE	EU
CRTN	UK	ISO 9613	EU
HARMONOISE/IMAGINE	EU	Aircraft noise method	Country
NMPB 2008	FR	AzB 2008	DE
Nord 2000	DK- FI - IS- NO- SE	ECAC Doc. 29 3 rd Ed.-ICAO doc. 9911	EU
RLS90 / VBUS	DE	FLULA	CH
RMW	NL	INM	US
RVS	AT	JCAB	JP
Sonroad	CH	NORTIM	NO
Railway traffic noise method	Country	HARMONOISE/IMAGINE	EU
CRN	UK		
HARMONOISE/IMAGINE	EU		
Nord 2000	DK- FI - IS- NO- SE		
Onorm 305011	AT		
RMR	NL		
Schall 03 / VBUSch	DE		
Semibel	CH		

The outcome of this evaluation exercise has been further undergone a critical debate in the context of the **Workshop on "Selection of common noise assessment methods in EU"** which was organised by the Joint Research Centre in liaison with DG ENV and EEA on **8-9 September 2009 in Brussels**. In this event, 30 noise experts participated including members from the EEA's EPoN group (Expert Panel on Noise) and model developers associated to the main existing noise methods in EU, USA and Japan for assessing road, railway, industrial and aircraft noise. During this event the elements the common noise assessment methods in the EU should be composed of were discussed and agreed upon.

Due to the fact that for some of the components of the common noise assessment methods further investigations were deemed appropriate before a consensus could be reached for these components, a series of ad-hoc meetings, benchmarking/testing and Workshops with various noise experts and stakeholders was planned and effectively took place in the period November 2009-March 2010. These events are listed below:

- **A Benchmarking/testing meeting on "Road traffic noise source and propagation (Harmonoise/Imagine, Nord2000. NMPB)", 17-18 November 2009, Brussels**
- **An ad hoc meeting on "Railway traffic noise (Harmonoise/Imagine and Schall03)", 7 December 2009, Ispra**
- **A Workshop on "Aircraft Noise Prediction" (based on ECAC Doc. 29, 3rd Ed. and AzB), 19-20 January 2010, Brussels**
- **An ad hoc meeting with software developers, 8-9 March 2010, Ispra**

Draft reports on the outcome of the aforementioned events are under preparation and as soon as they will be finalized they will be made available through the DG ENV's CIRCA website on noise (<http://circa.europa.eu/Public/irc/env/noisedir/library>).

I.1.6 Step 6: Drafting of the CNOSSOS-EU methodology along with guidelines for its competence use

On the basis of the outcome of step 5, the drafting of the CNOSSOS-EU methodological framework started in December 2009. This framework will include a description of the proposed common noise assessment methods for the four noise sources (i.e., road traffic, railway traffic, industrial and aircraft) along with a guidance document on its competence use in connection with data availability and in line with the two-level 'fit for purpose' framework. Concerning the preparation of the guidance document, priority will be given to the first purpose of strategic noise mapping which is the mandatory level of application of CNOSSOS-EU for the EU MS.

Integral part of the CNOSSOS-EU methodological framework will be also a strategy for attributing the number of people exposed to noise levels (a European expert working group will elaborate on this issue starting from September 2010) and the update of the END Reporting Mechanism (this latter task being coordinated by the European Environment Agency and expected to be completed by October 2010).

Execution of step 6 is underway and foresees the involvement of a wide number of noise experts in the drafting/reviewing process which is to be performed in two cycles. The first cycle is to be considered as preparatory of the second and formal cycle with the EU MS to be performed in the context of step 7.

I.1.7 Step 7: Consultation, review and finalization of CNOSSOS-EU together with the EU Members States

The 2nd cycle of reviewing CNOSSOS-EU is the most *crucial, central and formal cycle* of the reviewing process which will involve the representatives of the *EU MS* via the Noise Regulatory Committee. Step 7 will start with the organization of the next Noise Regulatory Committee meeting organized by DG ENV on 11 June 2010 in Brussels. This will concern both, the technical description of CNOSSOS-EU and its associated Guidance on the competence use of these methods for the two-level 'fit-for-purpose' framework of application of CNOSSOS-EU.

I.1.8 Step 8: Preparation of the operational part of CNOSSOS-EU

The main objective of step 8 is to produce an operational version of CNOSSOS-EU. This will include:

- ❖ The implementation of the CNOSSOS-EU methodological framework in a transparent and publicly available calculation code in a way to ensure the same implementation of the common methods throughout the EU MS, regardless of the commercial software used to perform the mapping exercise;

- ❖ The development of reference test cases for benchmarking the software implementing the CNOSSOS-EU calculation code;
- ❖ The setup and centrally updating by the EC appropriate databases of input values, by collecting relevant data from the existing national databases and research programmes, and adapt them to a common and standardised format. The standard format will allow the use of these data in the CNOSSOS-EU context and the comparability of existing data collected at national level will also allow identifying possible regional differences and analogies between the EU MS databases at both, national and local levels;
- ❖ To formulate a range of reference and real-life test cases under which CNOSSOS-EU will be verified and validated to ensure the appropriate quality of the results obtained through CNOSSOS-EU when performing the strategic noise mapping as foreseen by the Directive 2002/49/EC.
- ❖ To setup a quality system and a certification board for the maintenance and regular updating of the scientific/technical background of CNOSSOS-EU, its calculation code and the associated common database of input data on a long term basis. This will be managed with the direct involvement of EU MS, software developers and other relevant stakeholders deemed necessary.

The execution of step 8 is expected to start in July 2010 and progressively expand to a series of targeted activities to be defined in close co-operation with the EU MS.

I.1.9 Step 9: Long-term planning for assisting the EU MS to reliably implementing CNOSSOS-EU in the context of the future rounds of noise mapping in Europe

The whole implementation process of CNOSSOS-EU will be highly benefited not only from the guidelines for the competent use of the methods but also from the operation of a helpdesk service and potentially through the setup of a Community Reference Centre on Noise to be managed by the Joint Research Centre aimed at supporting the technical staff of the EU MS for quickly getting guidance and streamlining well targeted common activities related to implementation aspects of CNOSSOS-EU (some to them our outlined in the description of step 8 above). This will ensure to a great extent a smooth and harmonised implementation of the common methods in the EU MS during the forthcoming rounds of noise mapping in Europe.

Step 9 is expected to be undertaken at the end of 2010 / beginning of 2011.

I.2. Background and objectives of this report

The European Directive on the Assessment and Management of Environmental Noise (2002/49/EC) (END) defines obligatory actions for the EU Member States relating to the generation of strategic noise maps for main roads and railways, for main airports and for agglomerations. On the basis of these strategic noise maps, noise action plans should be drafted and published in order to inform the general public about the levels of noise they are exposed to.

One of the objectives of the END is to establish a common approach to assess the exposure to environmental noise throughout the European Union. For this purpose, a set of common noise indicators is defined in the Directive, viz. the day-evening-night level L_{den} and the night level L_{night} . The main objective of strategic noise mapping is to assess the exposure of people living

in agglomerations or in the vicinity of main roads, railways, industrial sites and airports via these common indicators.

This draft report defines a common assessment methodological framework (CNOSSOS-EU) which allows for a two-level application according to the objective of the assessment and compatible with the aforementioned common noise indicators. The first level of application allows performing an overall impact assessment of exposure to noise in the context of strategic noise mapping as required by the END with reasonable approximations and reduced computation time. At the second level of application, which requires a more precise determination of the noise levels, CNOSSOS-EU can also be used by the EU MS on a voluntary basis in its full version to assess the effectiveness of actions plans and potential new noise reduction measures.

CNOSSOS-EU has several commonalities with some of the methods currently used in the EU Member States, however, it is not identical to any of them.

CNOSSOS-EU addresses the noise sources defined in the Environmental Noise Directive (2002/49/EC), i.e.:

- Motorized road traffic sources, such as passenger cars, delivery vans and lorries and motorcycles, using standard infrastructure (road) including typical pavement types, both on main highways, local and regional roads.
- Rail traffic sources, such as locomotives, coaches, multiple units, freight wagon and light rail vehicles, using standard infrastructure (rail) including typical track superstructure types, both of national, regional or local networks.
- Industry sources such as machinery and equipment used for manufacturing industrial products, including mobile equipment used for internal transport, inside agglomerations.
- Air traffic sources such as winged aircraft (both jet engines and propeller engines and combinations thereof) and helicopters, in the direct vicinity of an airport, including ground activities such as taxiing and engine testing, and mobile equipment used for internal transport.

This draft report describes the methodological aspects of CNOSSOS-EU, however, this version does not yet include the input values and databases to be used for applying CNOSSOS-EU in practice. It should be underlined that, CNOSSOS-EU does not aim at covering the full range of existing national and regional peculiarities. However, in the Good Practice Guidelines for the competent use of CNOSSOS-EU to be prepared at a later stage, ways to introduce national or regional data will be described, for example particular road surface types or vehicle types used in some Member States.

The noise assessment to be performed via CNOSSOS-EU will rely to a great extent on the level of complexity of the methods used and on the availability and reliability of input data. Concerning the use of CNOSSOS-EU at the first –mandatory- level for strategic noise mapping, a simplified version of the method should be used with fewer requirements for input data and reduced overall computational time.

This draft report, suggests a set of simplifications, which have been, elaborated during the first phase of the drafting/reviewing of CNOSSOS-EU, which concern both, the source emission and propagation parts of the draft common noise methods. The aim is to further discussing this

set of simplifications with the EU MS starting from the next Noise Regulatory Committee meeting to take place in Brussels on 11 June 2010, and achieve consensus on the final set of simplifications to be included in CNOSSOS-EU along with the associated level of accuracy to be accepted for strategic noise mapping purposes.

In general, both the source description and the description of the surroundings (digital terrain model and built up area model) should both have compatible level of detail and accuracy. A detailed source model needs a detailed geometrical description in order to achieve a high level of accuracy in the result. Particularly, the heights of road and railway sources tend to be lower in the CNOSSOS-EU model than in existing national methods. This implies that the geometrical modelling of the immediate vicinity of such sources has to be carefully integrated.

It should be underlined that, the rationale of the methodological framework for common noise assessment along with the simplifications suggested as described in this draft report, is based on the discussions and consensus achieved among the noise experts involved during steps 1 to 5 of the CNOSSOS-EU roadmap. Therefore, the reader of this document to have a complete picture of the debate took place and the recommendations made during the events organised so far in the context of the CNOSSOS-EU roadmap, is invited to consult in parallel with this report also the outcome of these events. The reports of the two Workshops and minutes of the four ad hoc meetings are actually at their finalisation stage and will be made available via the DG ENV's CIRCA website (<http://circa.europa.eu/Public/irc/env/noisedir/library>) by 20 June 2010.

I.3. Definitions and symbols

I.3.1. General concepts

Line source / line source segment

A line source is an approximate trajectory of a moving equivalent point source. For practical reasons, a line source can be approximated by a set of straight-line segments (polyline), however, ideally, it could be represented by a curve in space.

A line source is characterised by a continuous distribution of point sources. The strength of a line source is expressed as sound power per meter. In practice, the continuous distribution of point sources will be replaced by a discrete distribution, i.e. equivalent point sources placed at representative positions along the source line.

The segmentation process consists of:

- 1) the splitting of source lines into smaller source line segments and
- 2) the replacement of the segments by equivalent point sources

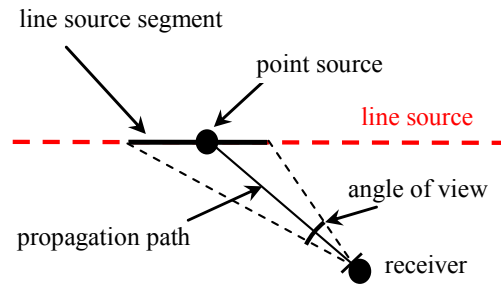

Figure I-1: Line source, line source segment, propagation path and angle of view

Propagation sector / angle of view

An angular sector drawn from the receiver to both ends of the line source segment. The angle between the lines from the receiver to both ends of the line source segment is called the angle of view of the propagation sector (figure I-1).

Propagation sectors may include reflections from nearly vertical obstacles by using the image of either the source or the receiver through the reflecting plane in place of the true position.

Homogeneous propagation sector

A propagation sector is considered to be homogeneous if:

- 1) the power of the source is almost constant over the source line segment, and
- 2) the excess propagation attenuation within the sector is slowly varying with the position along the source line

Within a homogeneous propagation sector, the line source segment can be replaced with a single equivalent point source and the excess attenuation can be calculated in a single representative propagation plane through this point source.

Point source

Line source segments will be represented by a number of mutually incoherent point sources at different height from which the acoustical energy radiates. Point source strength is expressed by the free-field source sound power level L_w per 1/1 or 1/3 octave band. All relevant parameters that define source strength will be incorporated, including horizontal and vertical directivity.

Point sources are situated at the intersections of each propagation path with each line source.

Vehicle model

The acoustical description of a single, moving vehicle at specific speed and acceleration. A single vehicle might be composed of several mutually incoherent sub-sources at different positions, the strength of which is defined in terms of their sound power level and directivity.

Traffic model

The acoustical description of a traffic flow, based on the sound power levels of single moving equivalent vehicles. In the traffic model, the specific sound power output is combined with

statistical data, yielding an equivalent noise emission for each sub-source **in order to produce the source strength of the relevant source line segments.**

N.B.: As a single vehicle can be represented by a set of point sources at different heights, the resulting traffic model will consist of a set of superimposed source lines that share a single footprint on the ground.

Receiver

A single point at which the incident time averaged sound intensity level will be calculated. A distinction should be made between free-field receivers that have propagation paths in all directions (360°) and receivers that represent the incoming acoustical energy on a façade. The latter will have a total viewing angle of 180° and a bisector perpendicular to the façade.

Propagation plane

A propagation plane is a vertical plane passing through the source and receiver positions. The intersection of the propagation plane with the geometrical (surface) model is represented by a series of connected line elements representing the terrain, the buildings and the barriers in a vertical cross-section. It is assumed that the effects of ground reflections, diffraction over obstacles and meteorological refraction can be predicted with sufficient accuracy from the geometrical and the acoustical properties in the cross-section.

An illustration of this approximation for the situation with barriers at an arbitrary angle to the source-receiver line is shown in figure I-2.

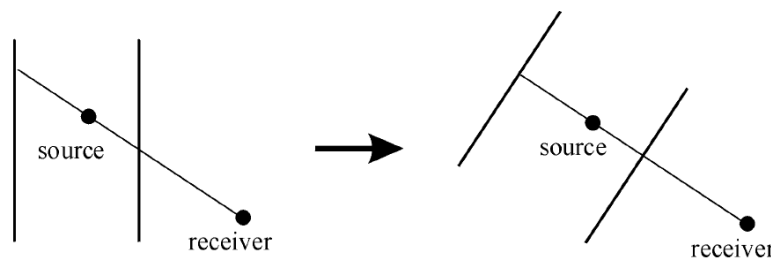

Figure I-2: Illustration of the 2-D approximation: the situation with barriers at an arbitrary angle to the source-receiver line (*left*) is replaced by a situation with barriers perpendicular to the source-receiver line (*right*) (from [5] in Chapter V).

Propagation path / geometrical cross-section

A propagation path is defined as the projection of a propagation plane on the horizontal plane. Propagation paths are essentially a 2-dimensional projected view of the site and the third dimension is added only to calculate the excess attenuation along these paths.

Propagation paths can be classified according to their geometrical characteristics:

- **Direct propagation paths** are straight lines linking the source directly to the receiver. This does not necessarily imply that the source is in direct view of the receiver: as the propagation path is constructed in 2-D it may pass over obstacles that block the line of sight.

- **Reflected propagation paths** are generated by vertical obstacles. It is assumed that such paths obey the laws of specular reflection in the horizontal plane. Note that reflections from the ground are taken into account by the Point-to-Point model and should not be considered as independent propagation paths.
- **Laterally diffracted propagation paths** are generated by vertical edges of obstacles. For extended (road, railway and aircraft) sources such paths usually have negligible contributions on the total sound levels and can therefore be omitted. For relatively small-sized sources (i.e. sources elements with size smaller than the propagation distance) like in the case of industrial areas or tunnel opening, the model may be extended to include such paths.
- Propagation paths containing any **combination** of reflections and diffractions from vertical obstacles.

Ray path

Each propagation path consists of a set of coherent ray paths. The shortest of these ray paths is called the “main ray path”; a ray path can be either direct (source in view of the receiver), reflected, diffracted or include any combination of these.

The main difference between ray paths and propagation paths is the way the different contributions are added: over propagation paths, incoherent summations are performed (addition of sound energies $|p|^2$) whereas over ray paths, coherent summations are performed (addition of sound pressures p).

The CNOSSOS-EU method uses coherent summation only for ray paths lying in a single vertical propagation plane (i.e. to estimate the effects of reflection on the ground). These effects are built into the point-to-point module described in chapter V. Different propagation paths, even when originating from a single point source, are always considered as incoherent.

CNOSSOS-EU is basically a 2.5D method in the sense that:

- 1) It operates on a 2.5D geometrical model, consisting in a connected set of surfaces that are either almost horizontal or almost vertical. Almost horizontal surfaces include terrain, roofs of buildings, road surfaces, etc. Almost vertical surfaces include barriers and façades of buildings.
- 2) Propagation paths and sectors are constructed in 2D, in the horizontal plane and include direct, reflected and diffracted paths. Direct paths include those diffracted over obstacles. Reflected paths come from almost vertical surfaces. Diffracted paths come from vertical edges shared by vertical planes.
- 3) Once a propagation path is found, it is converted into a propagation plane, derived from the intersection of a (set of) vertical plane(s) through the propagation path with the underlying 2.5D geometrical model. The outcome is a vertical cross section that is used as the input to the point-to-point module (section *V.1.1.c*).

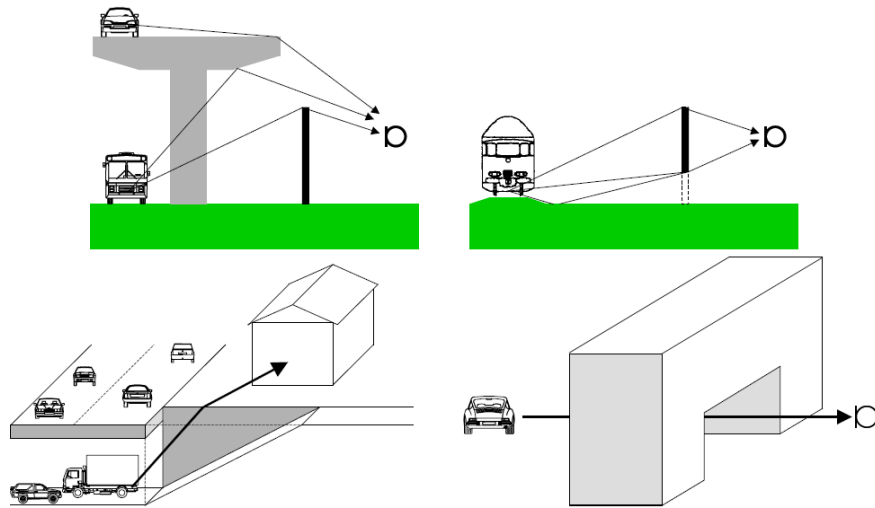

Figure I-2: Examples of ray paths in complex geometries (from [1] chap V)

The two upper cases in Fig.I-2 have additional ray paths compared with “regular” geometries. Advanced path detection methods are required in such cases. In the two lower cases, it is more efficient to use algorithms for propagation through tunnels and for radiation from openings rather than generating numerous (higher order) reflection paths.

N.B.: the CNOSSOS-EU methods are NOT intended to be used in combination with true 3D path finders.

Sound power

In the CNOSSOS-EU model, the acoustical emission of all sources is expressed as sound power emitted under free field conditions, i.e. excluding all effects from nearby obstacles. In general, and particularly for sources near the ground, this will lead to different values compared to those determined by means of the ISO standards aimed at estimating sound power levels in real operation. **Instructions for converting between these two approaches will be given in the Guidance for the Competent Use of CNOSSOS-EU.**

Meteorological effects

Wind speed and air temperature gradients cause refraction of the ray path. For accurate calculation of propagation effects such as barrier attenuation and ground reflections, the definition of the ray path must comply with defined meteorological conditions that are representative for the site. Therefore, a distinction will be made between e.g. downwind propagation (downward refraction), propagation under neutral conditions (straight propagation paths) and eventually, upwind propagation (upward refraction). Positive temperature gradients (“inversion”) have similar effects (if not more pronounced) as downwind conditions.

Meteorological data

Since the definition of the ray path depends on meteorological conditions, statistical data on temperature gradients, wind speed and wind directions in relation to source and receiver must be collected. Furthermore, meteorological conditions such as temperature, snow covering and precipitation influence the sound power output of the sources. Such input data may prove too difficult to obtain, in which case associated parameters might be used, e.g. cloud covering instead of vertical temperature gradients.

In practice, since meteorological conditions, especially wind speed and direction, can vary rapidly over time, a statistical classification of these meteorological conditions is necessary for modelling purposes. These meteorological classes must be defined such that variations within these classes have an acceptably small effect on the predicted noise levels. However, these meteorological classes must be realistic with regard to data collection and handling.

From each meteorological class, combined with possible variations in source strength, short term noise levels will be calculated. The yearly average noise indicators L_{den} and L_{night} can then be determined by the combination of these short-term noise levels with their occurrence.

I.3.2. One-third-octave bands

The CNOSSOS-EU method is valid for the frequency range from 25 Hz to 10 kHz. It provides 1/3-octave band results at the frequencies displayed in table I-1.

Based on these 1/3-octave band results, the A-weighted sound pressure level $L_{eq,T}$ is computed by summation over all frequencies:

$$L_{eq,T} = 10 \times \lg \sum_{i=1}^{27} 10^{(L_{eq,T,i} + A_{f,i})/10} \quad (I-2)$$

where $A_{f,i}$ denotes the A-weighting correction according to IEC 61672-1, given by table I-1.

Table I-1. Frequency range and A-weighting correction $A_{f,i}$

Index (i)	Freq [Hz]	$A_{f,i}$ [dB]	Index (i)	Freq [Hz]	$A_{f,i}$ [dB]	Index (i)	Freq [Hz]	$A_{f,i}$ [dB]
1	25	-44.7	10	200	-10.9	19	1600	+1.0
2	31.5	-39.4	11	250	-8.6	20	2000	+1.2
3	40	-34.6	12	315	-6.6	21	2500	+1.3
4	50	-30.2	13	400	-4.8	22	3150	+1.2
5	63	-26.2	14	500	-3.2	23	4000	+1.0
6	80	-22.5	15	630	-1.9	24	5000	+0.5
7	100	-19.1	16	800	-0.8	25	6300	-0.1
8	125	-16.1	17	1000	0.0	26	8000	-1.1
9	160	-13.4	18	1250	+0.6	27	10000	-2.5

Simplified method	It is recommended that, modelling with calculations in full octave band is sufficient for the simplified version of CNOSSOS-EU.
-------------------	---

I.3.3. Indicators

Noise indicators

The long-term average noise indicator specified in the European Directive 2002/49/EC, is the day-evening-night indicator, L_{DEN} defined by:

$$L_{DEN} = 10 \lg \left[\frac{12}{24} 10^{L_{day}/10} + \frac{4}{24} 10^{(L_{evening}+5)/10} + \frac{8}{24} 10^{(L_{night}+10)/10} \right] \quad (I-1)$$

where

L_{day} (respectively $L_{evening}$ and L_{night}) is the A-weighted long-term average sound level, as defined in ISO 1996-2: 1987, determined over all the day (respectively evening and night) periods of a year.

The day is 12 hours, the evening four hours and the night eight hours, and a year is a relevant year as regards the emission of sound and an average year as regards the meteorological circumstances.

The parameters used in the various formulations are usually defined locally in the respective sections. However, as some parameters are common to the formulations in several chapters, they are summarised in the tables below.

Noise parameters:

L_p	instantaneous sound pressure level	[dB] (re. $2 \cdot 10^{-5}$ Pa)
L_{eq,T_p}	equivalent sound pressure level during the period T_p	[dB] (re. $2 \cdot 10^{-5}$ Pa)
L_{Aeq,T_p}	A-weighted equivalent sound pressure level during the period T_p	[dB(A)] (re. $2 \cdot 10^{-5}$ Pa)
$L_{eq,passby}$	equivalent sound pressure level for a single vehicle pass-by	[dB] (re. $2 \cdot 10^{-5}$ Pa)
L_W	sound power level of a point source (moving or steady)	[dB] (re. 10^{-12} W)
$L_{W,0}$	instantaneous sound power level of the single vehicle	[dB] (re. 10^{-12} W)
$L_{W,0,dir}$	directional sound power level of the specific noise	[dB] (re. 10^{-12} W)
$L_{W'}$	average sound power level per meter of equivalent line of point sources	[dB] (re. 10^{-12} W)
$L_{W',eq,line}$	average directional sound power per meter length	[dB] (re. 10^{-12} W)
$L_{W',tot,dir}$	average directional sound power per meter length of the equivalent sound source (due to all contributions from different $L_{W',eq,line}$)	[dB] (re. 10^{-12} W)
$L_{W,dir,low}$	directional sound power level of the lowest source	[dB] (re. 10^{-12} W)
$L_{W,dir,high}$	directional sound power level of the highest source	[dB] (re. 10^{-12} W)
$\Delta L_{W,dir}$	directivity correction for the single moving point source (used in measurements and to convert L_{eq} , L_{AeqT_p} from other methods/databases)	[dB] (re. 10^{-12} W)
$\Delta L_{W,tot,dir}$	total directivity correction	[dB] (re. 10^{-12} W)
$\Delta L_{W,dir,vert}$	vertical directivity correction	[dB] (re. 10^{-12} W)
$\Delta L_{W,dir,hor}$	horizontal directivity correction	[dB] (re. 10^{-12} W)
$\Delta L_{W,dir,i}$	directivity correction for the single (fixed) point source on the equivalent line of point sources (used in calculations)	[dB] (re. 10^{-12} W)

Other physical parameters:

x	position along the X-axis	[m]
X	minimum distance source to line of equivalent point sources	[m]
d	distance source to single point source (possibly at a given time) on the line	[m]
y	position on the Y axis	[m]
Y	length along which the point sources considered extend on the Y' axis	[m]
V	vehicle speed	[km/h]
T_{ref}, T_p	reference time periods	[s] or [h]
α	coefficient for directivity definition	
β	coefficient for directivity definition	
φ	angle for the definition of the horizontal directivity	[rad]
ψ	angle for the definition of the vertical directivity	[rad]
Q	number of vehicles per second	[s ⁻¹]
N	number of vehicles per train	
l_{veh}	length of the railway vehicle (buffer to buffer)	[m]
f	frequency	[Hz]
p	r.m.s. of the instantaneous sound pressure	[Pa]
p_0	reference sound pressure = $2 \cdot 10^{-5}$ Pa	[Pa]
ρ_0	air density (@15°C and 1atm)	[kg m ⁻³]
c_0	sound speed (@15°C and 1atm)	[m s ⁻¹]
k_0	wavenumber ($k_0=2\pi f/c_0$)	[m ⁻¹]
τ, τ_{ref}	temperature, reference temperature	[°K]
W	point source sound power	[Watt]
W_0	reference sound power = 10^{-12} W	[Watt]
D	directivity correction factor	

CHAPTER II. ROAD NOISE SOURCE EMISSION

II.1. Source description

II.1.1. Classification of vehicles

Road traffic noise results from the addition of the noise emission of each individual vehicle forming the traffic flow. These vehicles can be grouped into four categories with regard to their characteristics of noise emission:

Category 1: *Light motor vehicles*

Category 2: *Medium heavy vehicles*

Category 3: *Heavy vehicles*

Category 4: *Powered two wheelers*

In the case of powered two-wheelers, two separate subclasses are defined for mopeds and more powerful motorcycles, since they operate in very different driving modes and their occurrence usually differs strongly.

The details of the different vehicle classes are given in Table II.1.

Table II.1 - Vehicle classes

Category	name	description	vehicle category in EC Whole Vehicle Type Approval ⁽¹⁾
1	Light motor vehicles	Passenger cars, delivery vans \leq 3.5 tons, SUV's ⁽²⁾ , MPV's ⁽³⁾ including trailers and caravans	M1 and N1
2	Medium heavy vehicles	Medium heavy vehicles, delivery vans $>$ 3.5 tons, buses, touring cars, etc. with two axles and twin tyre mounting on rear axle	M2, M3 and N2, N3
3	Heavy vehicles	Heavy duty vehicles, touring cars, buses, with three or more axles	M2 and N2 with trailer, M3 and N3
4	Powered two-wheelers	4a mopeds, tricycles or quads \leq 50 cc	L1, L2, L6
		4b motorcycles, tricycles or quads $>$ 50 cc	L3, L4, L5, L7

⁽¹⁾ Directive 2007/46/EC of the European Parliament and of the Council of 5 September 2007 (OJ L 263/1 9/10/2007) establishing a framework for the approval of motor vehicles and their trailers, and of systems, components and separate technical units intended for such vehicles.

⁽²⁾ Sport Utility Vehicles

⁽³⁾ Multi-Purpose Vehicles

Off-road vehicles (ORV) are not covered by this CNOSSOS-EU.

More vehicle categories or sub-categories can be defined to take into account traffic fleet specificities [1]. However, they are not covered in CNOSSOS-EU because they are of less practical interest since detailed distribution of traffic into detailed sub categories is rarely available. Such specificities as shifts in axle configurations of trucks, or an exceptionally high

amount of vans can be dealt with by applying the corrections of regional specificities described in section II.3.3.

Simplified method	<p>In some cases, separate traffic data for categories 2 and 3 are not available or the proportion of vehicles in one of these category is low. In this case, it is recommended that, a nationally established default decomposition of heavy vehicles into the two categories can be used, based on type of road under study. Alternatively, if one of the two categories dominates the flow strongly, this category is recommended to be used for the whole traffic flow.</p> <p>In some cases, it is an acceptable simplification to neglect category 4, if the traffic data for this category is unavailable or if the vehicle fleet is not significant.</p>
--------------------------	--

II.1.2. Number and position of equivalent sound sources

For the calculation of noise propagation and for the determination of sound power emission, it is necessary to describe the source with one or several point sources. In this method, each vehicle (Cat. 1, 2 and 3) is represented by two point sources, each of them being assigned a sound power level gathering contributions from both rolling and propulsion noise source. Two-wheelers (Cat. 4) are represented by one point source only, since the contribution of rolling noise for these vehicles is assumed negligible.

As depicted in figure II.1, the positions of the point sources are:

- Light motor vehicles (Cat. 1) are represented by two equivalent point sources: the lowest one is located at 0.01 m above the road, the highest one at 0.30 m above the road.
- Heavy motor vehicles (Cat. 2 and 3) are represented by two equivalent sources: the lowest one is located at 0.01 m above the road and the highest one at 0.75 m above the road.
- Two-wheelers (Cat. 4) are represented by one point source only, located at 0.30 m above the road.

In the first two cases (Cat. 1, 2 and 3), the lowest source carries 80% of the rolling sound power and 20% of the propulsion sound power, whereas the highest source carries 20% of the rolling noise and 80% of the propulsion noise. This power distribution was chosen to consider the fact that in reality sources are distributed rather than concentrated at point sources [3].

About 1% of heavy vehicles have a high exhaust system, which may alter significantly the noise emission characteristics and make the model with two equivalent point sources inaccurate. In general, this peculiarity can be neglected. In the case of a significantly higher proportion of such particular heavy vehicles (for instance, close to building sites where many construction trucks are present) and when combined shielding effects are included in the configuration, an additional point source 3.50 m high should be used. All sound power of propulsion noise at and below 315 Hz is assigned to this source, for frequencies above 315 Hz, the original distribution between 0.01 m and 0.75m positions for low and high sources remain identical.

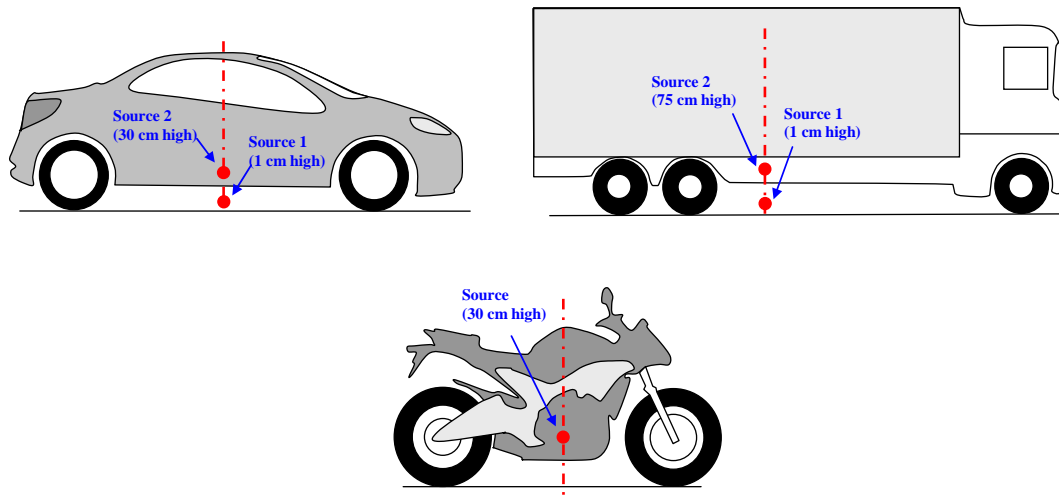

Figure II.1: Location of equivalent point source on light vehicles (cat.1), heavy vehicles (cat.2 and 3) and two-wheelers (cat.4).

The vertical resolution of the sources is relevant both for the calculation of the sound propagation and for the determination of the sound power emission. In general, sound power emission of vehicles derives from a best fit between measurements of sound pressure on the road side and sound propagation theoretical calculations. Thus, in this short range, vertical resolution of the equivalent sources is important especially because it strongly affects the interference between direct and reflected components on the ground. **The method for deriving sound power levels from roadside sound pressure measurements will be described in the Guidance for the competent use of CNOSSOS-EU.**

Horizontal resolution in the driving direction is not taken into account since the traffic stream, or part of it, is represented by a line source. This line source is located in the vertical plane of the centre of the driveway. The sound power of the source is defined as the total sound power in free field, without any disturbing objects in its surrounding, in particular without any reflection on the road surface. The radiation in different directions is given by a directivity function in both horizontal and vertical planes, as described in section II.2.7.

Simplified method	<p>On inter-urban roads, in the case of fast (above 50 km/h) and quite steady traffic, it is recommended to consider only the lowest noise source. This, in general, is coherent with existing databases for rolling noise.</p> <p>In general, the peculiarity of heavy vehicles with high exhaust system can be neglected. It is recommended to treat these vehicles, similarly as vehicles in category 3.</p> <p>In the case of a multiple carriageway, it is recommended to allow for further simplifications on the number of source lines to consider (e.g., one source line per driving direction).</p>
-------------------	---

II.2. Sound power emission

II.2.1. General considerations

Individual vehicle

The model for road traffic noise describes the noise emission of an "average" European road vehicle in terms of sound power level. It defines the instantaneous noise production of a vehicle defined by the two main parameters - category, speed - and corrected for several environmental or specific effects. The calculations are performed with separate speeds for Cat. 1, Cat. 2 and 3 and for Cat. 4. Usually, these speeds are dependent on the maximum allowed speed of the road for each category. This description is consistent with the propagation calculation scheme detailed in Chapter VI.

For each road vehicle, the emission model consists of a set of mathematical equations representing the two main noise sources:

1. Rolling noise due to the tyre/road interaction;
2. Propulsion noise produced by the driveline (engine, exhaust, etc.) of the vehicle;

Aerodynamic noise is incorporated in the rolling noise sources, since the chosen method of determination of the sound power level determined from coast-by events makes it impossible to distinguish between the two. The effect of aerodynamic noise on the source height can be neglected since detailed measurements have demonstrated that the sources for flow noise are also located in the wheel arches and under the car. Aerodynamic noise is considered to be of influence only at high vehicle speeds.

The general form of the mathematical expression for the sound power level emitted by one of the sources (rolling or propulsion) as a function of the vehicle speed v ($20 \text{ km/h} \leq v \leq 130 \text{ km/h}$) is:

$$L_{W,i,m}(v) = A_{i,m} + B_{i,m} \cdot f(v) \quad (II-1)$$

with $f(v)$ being either a logarithmic function of the vehicle speed v in the case of rolling and aerodynamic noise, and a linear function of v in the case of propulsion noise. The sound power level $L_{W,i,m}$ is calculated in 1/3-octaves from 25 Hz to 10 kHz, where the subscript i indicates the spectral frequency band. The index m represents the vehicle category as defined in section II.1.1.

For two-wheelers (Cat. 4), only propulsion noise is considered for the single equivalent point source.

For light and heavy motor vehicles (Cat. 1, 2 and 3), the sound power is usually distributed between two point sources. Actually, rolling and propulsion noise are distributed with an 80%-20% sharing ratio. Thus, the apparent directional sound power level of the lowest source ($L_{W,dir,low,i,m}$) and the apparent directional sound power level of the highest source ($L_{W,dir,high,i,m}$) for $m=1,2$ or 3 are defined by:

$$L_{W,dir,low,i,m}(v) = 10 \times \lg \left(0.8 \times 10^{L_{WR,i,m}/10} + 0.2 \times 10^{L_{WP,i,m}/10} \right) + \Delta L_{W,dir,i,m} \quad (II-2)$$

$$L_{W,dir,high,i,m}(v) = 10 \times \lg \left(0.2 \times 10^{L_{WR,i,m}/10} + 0.8 \times 10^{L_{WP,i,m}/10} \right) + \Delta L_{W,dir,i,m} \quad (II-3)$$

where $L_{WR,i,m}$ is the sound power level for rolling noise and $L_{WP,i,m}$ is the sound power level for the propulsion noise. They can be calculated by equation (II-1).

$\Delta L_{W,dir,i,m}$ accounts for the directivity of the sources. The calculation is detailed in section II.2.6.

Simplified method	Directivity data are rarely available. Furthermore, it was observed [ref] that except at low speeds, the vehicle noise source is close to omni-directional. Therefore, it is recommended to omit the corrections for directivity as an acceptable simplification.
-------------------	---

N.B.: In the rest of this chapter, all the sound power levels and correction coefficients are expressed for each category m ($m = 1$ to 4) and for each 1/3-octave band i ($i = 1$ to 27) in the range [25 Hz – 10 kHz]. By default, the subscripts “ i ” and “ m ” are implicit in all the indicators, but they will be omitted to improve the readability of the text.

Traffic flow

The noise emission of a traffic flow is represented by a line source characterised by its sound power per unit length. This corresponds to the sum of the sound emission of the individual vehicles in the traffic flow, taking into account the time spent by the vehicles in the considered road section. The implementation of the individual vehicle in the flow requires the application of a traffic flow model ([4], [5]).

If a steady flow of N vehicles during the period T (in seconds) is assumed, with an average speed V (in m/s), the noise emission of the vehicle flow in terms of an equivalent line source strength (average sound power level per unit length) $L_{W',eq,line}$ is defined by:

$$L_{W',eq,line} = L_{W,0} + 10 \times \lg \left(\frac{N}{T \times V} \right) \quad (II-4)$$

where $L_{W,0}$ is the instantaneous and directional sound power level of the lowest or the highest noise source of a single vehicle according to equation (II-2) or (II-3). In equation (II-4), the unit length is meter, $L_{W',eq,line}$ is expressed in dB/m (re. 10^{-12} W).

In the case of a unit length in kilometre, adequate conversion constants give:

$$L_{W',eq,line} = L_{W,0} + 10 \times \lg \left(\frac{Q}{1000 \times v} \right) \quad (II-5)$$

where Q is the vehicle flow in vehicle per hour and v the average speed in km/h.

Using this formula, the L_{WR} and L_{WP} contributions for rolling and propulsion noise have to be calculated separately and distributed over the vertical source positions as described in equations (II-2) and (II-3). The result is then the $L_{W',eq,line}$ for the entire vehicle flow, distributed over the three different source heights.

II.2.2. Reference conditions

The source equations and coefficients are derived to be valid under reference conditions for meteorology and traffic situation. These reference conditions are:

- constant vehicle speed,
- a flat road, i.e. with a slope s (in %), such as $|s| \leq 2\%$
- an air temperature $\tau_{ref} = 20$ °C,
- a virtual reference road surface, consisting of a mixture of DAC 0/11 and SMA 0/11 with an age between 2 and 7 years and in a representative maintenance condition. Sound reflection properties are assumed on this reference surface.
- a dry road surface,
- a vehicle fleet representing the average of vehicles over the whole of Europe:
 - ◊ 187 mm tyre width for Category 1,
 - ◊ 19% diesel for Category 1,
 - ◊ 10.5% delivery vans in Category 1,
 - ◊ no studded tyres,
 - ◊ 4 axles for Category 3,

For situations deviating from these reference conditions, correction factors are introduced, as described in the following sections.

II.2.3. Rolling noise

II.2.3.a. General equation

For rolling noise, the generally accepted and widely validated logarithmic relation between rolling noise emission and rolling speed v is used. The sound power level L_{WR} is expressed by:

$$L_{WR} = A_R + B_R \times \lg\left(\frac{v}{v_{ref}}\right) + \Delta L_{WR,road} + \Delta L_{WR,region} \quad (II-6)$$

The coefficients A_R and B_R are given in Appendix II-A in 1/3-octave bands for each vehicle category, and for a reference speed $v_{ref} = 70$ km/h. They are defined in the reference conditions described in section II.2.2.

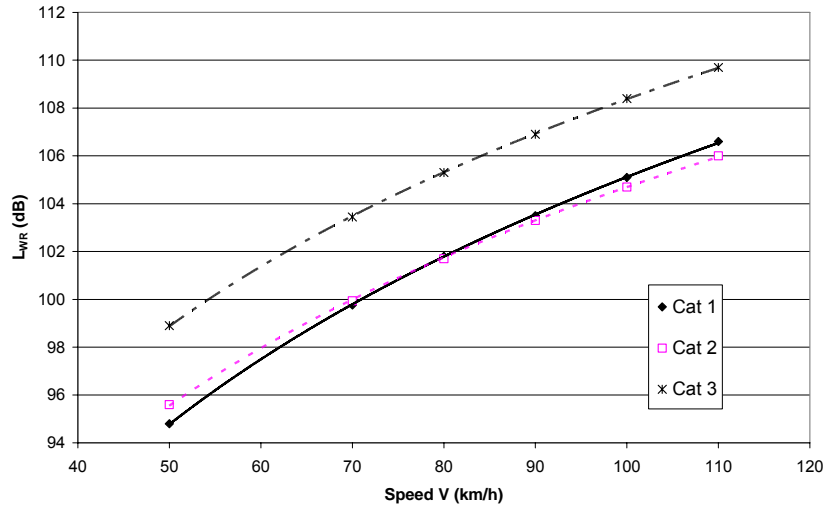

Figure II.2: Rolling sound power levels in dB for the first three categories of vehicles in reference conditions.

$\Delta L_{WR,road}$ is a correction related to the road surface type and condition. It is detailed in section II.2.5. This correction is of first order of importance.

$\Delta L_{WR,region}$ is the regional correction coefficient. It corresponds to the sum of several correction coefficients related to regional specificities, to be applied on the rolling noise emission for actual conditions deviating from the reference conditions. It can be expressed as the addition of the correction coefficient related to road surface environment ($\Delta L_{WR,env}$) and the correction coefficient related to vehicle fleet specificities ($\Delta L_{WR,fleet}$). These corrections are of a second order of importance.

$$\Delta L_{WR,region} = \Delta L_{WR,env} + \Delta L_{WR,fleet} \quad (II-7a)$$

where
$$\Delta L_{WR,env} = \Delta L_{WR,temp} + \Delta L_{WR,wet} \quad (II-7b)$$

and
$$\Delta L_{WR,fleet} = \Delta L_{WR,2tyr} + \Delta L_{WR,axle} + \Delta L_{WR,stud} + \Delta L_{WR,wid} + \Delta L_{WR,vans} \quad (II-7c)$$

$\Delta L_{WR,temp}$ and $\Delta L_{WR,wet}$ account for deviations related respectively to the road surface temperature, wetness. They are detailed in section II.3.1.a to c;

$\Delta L_{WR,2tyr}$, $\Delta L_{WR,axle}$, $\Delta L_{WR,stud}$, $\Delta L_{WR,wid}$ and $\Delta L_{WR,vans}$ account for regional type of deviation in the vehicle fleet. They are detailed in section II.3.2.

If reference conditions are assumed, then: $\Delta L_{WR,road} = \Delta L_{WR} = 0$

As stated above, the aerodynamic noise of the vehicle is incorporated in the rolling noise equation.

Simplified method	<p>In case of data unavailability, it is recommended that the speed of the traffic to be handled as default value corresponding to the maximum permitted speed of the road section of interest.</p> <p>It is also recommended that, the regional correction coefficient to be totally or partially omitted in the simplified version of CNOSSOS-EU because the effect on noise of the different coefficients is of second order and also because data for the calculation of the different coefficients may not be available in most situations.</p>
-------------------	--

II.2.4. Propulsion noise

II.2.4.a. General equation for steady speed conditions

The propulsion noise emission includes all contributions from engine, exhaust, gears, air intake, etc. For propulsion noise, the emission L_{WP} is formulated as follows:

$$L_{WP} = A_P + B_P \times \frac{(v - v_{ref})}{v_{ref}} + \Delta L_{WP,road} + \Delta L_{WP,other} \quad (II-8)$$

The coefficients A_P and B_P are given in Appendix II-A in 1/3-octave bands for each vehicle category, and for a reference speed $v_{ref} = 70$ km/h. They are defined in the reference conditions described in section II.2.2, in particular for a vehicle at a steady speed on a flat road.

$\Delta L_{WP,road}$ is the correction coefficient due to the effect of road surface on propulsion noise. It is defined in section II.2.5. $\Delta L_{WP,other}$ corresponds to the sum of the correction coefficients to be applied on propulsion noise emission for specific driving conditions or actual regional conditions deviating from the reference conditions:

$$\Delta L_{WP,other} = \Delta L_{WP,acc} + \Delta L_{WP,grad} + \Delta L_{WP,vans} + \Delta L_{WP,diesel} \quad (II-9)$$

$\Delta L_{WP,acc}$ and $\Delta L_{WP,grad}$ account for deviations related to the driving conditions. They are detailed in sections II.2.4.b to d;

$\Delta L_{WP,vans}$ and $\Delta L_{WP,diesel}$ account for regional type of deviation in the vehicle fleet. They are detailed in section II.3.3.d and II.3.3.e.

If reference conditions are assumed, then: $\Delta L_{WP,region} = \Delta L_{WP,road} = 0$

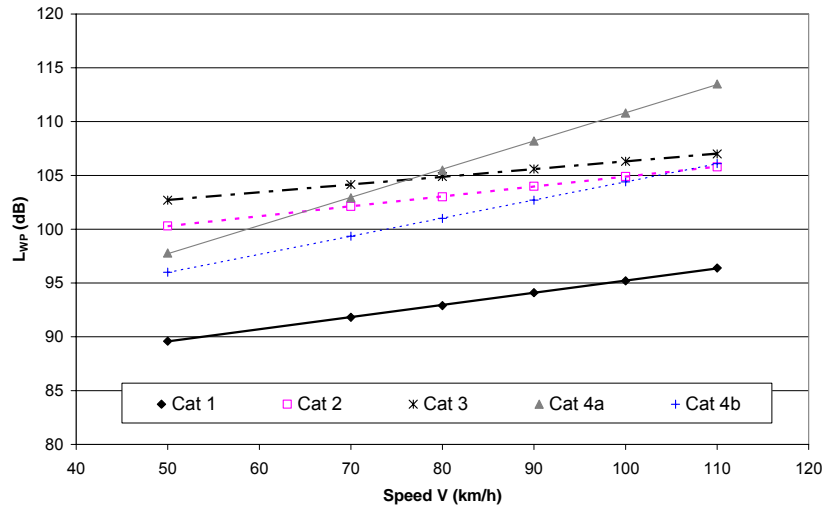

Figure II.3: Traction sound power levels in dB for all categories of vehicles in reference conditions.

The equation (II-8) is based on a combination of the relation between vehicle speed and engine speed and the relation between engine speed and noise. The first relation is mainly steered by the gear shifting behaviour of the driver. Several field tests have shown that although the driver operates the vehicle in a limited engine speed range, there is a clear tendency for higher engine speeds at higher vehicle speeds. The resulting linear relation between noise emission and vehicle speed is a reasonable approximation.

II.2.4.b. Acceleration and deceleration of vehicles

For the propulsion noise of accelerating and decelerating vehicles on a flat road, a correction $\Delta L_{WP,acc}$ is developed based on the actual (instantaneous) vehicle acceleration a in m/s^2 :

$$\Delta L_{WP,acc} = \begin{cases} C_P \cdot a & \text{for } a \geq -1 \text{ m/s}^2 \\ C_P \cdot (-1) & \text{for } a < -1 \text{ m/s}^2 \end{cases} \quad \text{with } |a| \leq a_{max} \quad (II-10)$$

This correction is valid only for moderate acceleration values. The maximum acceleration to be considered is equal to:

$$a_{max} = \begin{cases} 2 \text{ m/s}^2 & \text{for category 1} \\ 1 \text{ m/s}^2 & \text{for categories 2 and 3} \\ 4 \text{ m/s}^2 & \text{for category 4.} \end{cases} \quad (II-11)$$

The coefficients C_P are given in Appendix II.A.1 for each 1/3-octave frequency band and for each vehicle category. The coefficients are equal for categories 1 and 4, as well as for categories 2 and 3.

Simplified method	The acceleration at the scale of a traffic flow is much more difficult to estimate than for individual vehicles, as it depends on the behaviour of individual vehicles, location, time, traffic conditions, etc Thus, the uncertainty on the estimation of acceleration of the traffic is higher than the effect on noise. Therefore, it is recommended to neglect the acceleration in the simplified version of CNOSSO-EU.
-------------------	---

II.2.4.c. Effect of road gradients

Road gradient has two effects on noise emission: first, it affects the vehicle speed and thus their rolling and propulsion noise emission; second, it affects the engine load and thus the propulsion noise emission of the vehicle. Only this second effect is considered in this section, where a steady speed is assumed. It was observed that road gradients lower than 6% have no effect on the propulsion noise of light motor vehicles (Cat. 1) [8].

Three conditions of road gradients are considered, according to the slope s (in %):

- Flat road: for $|s| \leq 2\%$, the road gradient is neglected
- Uphill conditions: for $2\% \leq s \leq 6\%$

- Downhill conditions: for $-6\% \leq s \leq -2\%$

The effect of road gradient on the propulsion noise is taken into account by a correction coefficient $\Delta L_{WP,grad}$ according to the slope s [8]:

$$\text{For } m = 1 \text{ or } 4 \quad \Delta L_{WP,grad} = 0 \quad \text{for all } |s| \leq 6\% \quad (II-12)$$

$$\text{For } m = 2 \text{ or } 3 \quad \Delta L_{WP,grad} = \begin{cases} 0 & \text{for } |s| \leq 2\% \\ 2 \times (s - 2) & \text{for } 2\% \leq s \leq 6\% \\ |s| - 2 & \text{for } -6\% \leq s \leq -2\% \end{cases} \quad (II-13)$$

This correction is valid only for vehicles at steady speed $v > 20$ km/h.

N.B.: *The corrections have been established for slopes $|s| \leq 6\%$. For steeper slopes $|s| > 6\%$, corrections can be defined with help of specific measurements as described in [8], by comparing pass-by noise levels on flat and on non flat parts of the road. The measurement protocol has to differentiate rolling and propulsion noise. An alternative approximate solution is to use the correction coefficient at $|s| = 6\%$. However, the uncertainty is unknown.*

II.2.4.d. Combined effect of road gradient and acceleration for heavy vehicles (Cat.2 and 3)

The combination of road gradient and acceleration or deceleration of heavy vehicles (Cat. 2 and 3) does not result in the sum of both effects [8]. In this case, the following corrections are applied for both effects:

In the case of uphill conditions ($2\% \leq s \leq 6\%$):

$$\Delta L_{WP,acc} + \Delta L_{WP,grad} = \begin{cases} \text{Max}\{2 \times (s - 2); 5\} & \text{for acceleration conditions} \\ 0 & \text{for deceleration conditions} \end{cases} \quad (II-14)$$

In the case of downhill conditions ($-6\% \leq s \leq -2\%$):

$$\Delta L_{WP,acc} + \Delta L_{WP,grad} = \begin{cases} 5 & \text{for acceleration conditions} \\ (|s| - 2) & \text{for deceleration conditions} \end{cases} \quad (II-15)$$

Simplified method	For the same reason as for acceleration, it is recommended to neglect the combined effect of road gradient and acceleration for heavy vehicles (Cat. 2 and 3) in the simplified version of CNOSSOS-EU; only the gradient effect will be considered.
-------------------	---

II.2.5. Effect of the type of road surface

II.2.5.a. General principle

The type of road surface significantly influences the noise emission of a vehicle. On a single pass-by event on the road side, differences up to 15 dB(A) can be observed for the same vehicle at the same speed in conditions where rolling noise is predominant.

The variety of road surface types and conditions over Europe is large, leading to significantly different noise related properties across Europe. Currently there is no common procedure for the assessment of road surface noise properties, although collective suggestions for acoustical classification, checking and monitoring of road surfaces have been made [6].

The road surface characteristics affect mainly rolling noise emission, but porous sound absorbing surfaces also affect the propagation of rolling and propulsion noise. However, in practice, the effect of a road surface is usually evaluated according to international standard procedures, by comparing sound pressure levels measured on the road side that include both source and propagation effects. Therefore, the correction factors proposed in this method for the effect of road surface include implicitly the effect of the surface on local sound reflection. Consequently, they should apply to both rolling and propulsion noise and the change in surface impedance shall not be included in propagation calculations. They are based on a set of experimental data acquired on a representative selection of EU road surfaces [2].

- The **rolling noise** emission defined in equation (II-6) with coefficients in Appendix II-A is valid for a virtual reference road surface defined in section II.2.2.

For other road surfaces, it is recommended to apply a correction procedure based on a classification and labelling system as described in [6]. This procedure distinguishes between the effect on light motor vehicles (Category 1) and on that of heavy duty vehicles (Categories 2 and 3). The procedure also includes the spectral effect. Porous surfaces in particular exhibit strong spectral differences that, when neglected, lead to errors in propagation calculations over barriers, over long distances or through facades.

The effect of the road surface on the rolling noise level is given by:

$$\Delta L_{WR,road} = \alpha_{i,m} + \beta_m \times \lg\left(\frac{v}{v_{ref}}\right) + \Delta L_{WR,age} \quad (II-16)$$

where : $\alpha_{i,m}$ is the spectral correction in dB at reference speed v_{ref} for category m (1, 2 or 3) and spectral band i (1/3-octave bands from 50 to 10000 Hz).

β_m is the speed effect on rolling noise reduction. Although this coefficient is in principle frequency dependent, no spectral data are available in the literature and a constant value is assumed in this method.

$\Delta L_{WR,age}$ is a correction term accounting for the age of the road surface. It is described in section II.2.5.b.

Some examples of numerical values obtained on a large set of road surfaces in the Netherlands [1] for $v_{ref} = 70$ km/h are given in Appendix II-C. **How to derive values from national emission databases will be described in the Guidance for the competent use of CNOSSO-EU.**

- For **propulsion noise**, the surface effect is originating from absorption of sound in the process of reflection against the road surface under and close to the vehicle body. It is defined as a single spectrum reduction, only depending on vehicle category and on spectral band:

$$\Delta L_{WP,road} = \text{Max} \{ \alpha_{i,m}; 0 \} \quad (II-17)$$

For dense road surfaces, there is no correction for road surface on propulsion noise. For porous road surfaces, the correction is identical to that for rolling noise at the reference speed, but with a maximum of zero. Thus, porous surfaces will decrease the propulsion noise, but dense surfaces will not increase it.

II.2.5.b. Age effect on road surface noise properties

Noise characteristics of road surfaces vary with age, with a tendency to become louder over time. In particular, the acoustic lifetime of low noise surfaces is usually shorter than the one of dense surfaces, especially concrete surfaces. It is recommended that acoustic monitoring procedures such as described in [6] are applied on a regular basis to determine experimentally the $\Delta L_{WR,age}$. In this way, noise emission data should be regularly updated by introduction of updated noise performances of road surfaces according to the procedure described in section II.2.4.a.

In the absence of monitoring, a default correction of the rolling noise can be introduced for porous surfaces [7].

- for non-porous surfaces, the ageing effect is neglected:

$$\Delta L_{WR,age} = 0$$

- for porous surfaces, like Porous Asphalt Concrete (PAC), Porous Cement Concrete (PCC), Poro-Elastic Road Surface (PERS) and Open Graded Asphalt Concrete (OGAC), the ageing of acoustic properties can be taken into account by the following expression:

$$\Delta L_{WR,age} = \Delta L_{WR,age,0} \times (1 - (0.25 Y - 0.016 Y^2)) \quad \text{for } Y \leq 7 \text{ years} \quad (II-18)$$

where Y is the age of the road surface in years, $\Delta L_{WR,age,0}$ is the A-weighted sound pressure level relative the reference surface at the time $Y = 0$ year.

As this formulation was established on A-weighted levels only, it should be applied equally on all frequency bands.

Simplified method	In the simplified version of CNOSSOS-EU, it is recommended to apply no correction for the ageing of road surfaces. However, this ageing effect can be implicitly taken into account in the correction for road surface type, by considering an average $\Delta L_{WR,road}$ of the road surface over the years.
-------------------	---

II.2.6. Source directivity

In theory, the point sources should be assigned both horizontal and vertical directivity. The directivity correction with respect to an omni-directional sound power is defined as the summation of a horizontal and a vertical term:

$$\Delta L_{W,dir} = \Delta L_{W,dir,hor} + \Delta L_{W,dir,vert} \quad (II-19)$$

However, for road vehicles, the horizontal directivity can reasonably be neglected. Furthermore, in simple cases of general modelling, when no strong heterogeneities in the propagation path exist (for example, no barrier edge in the vicinity), the frequency dependence can be neglected for vertical directivity. The relation can be approached by the following linear function:

$$\begin{aligned} \Delta L_{W,dir} &= -\frac{9}{\pi} \Psi && \text{for category } m = 1 \\ \Delta L_{W,dir} &= -\frac{6}{\pi} \Psi && \text{for category } m = 2 \text{ and } 3 \end{aligned} \quad (II-20)$$

Ψ is the vertical propagation angle with respect to the horizontal plane containing the contact points between the vehicle wheels and the road surface (figure II-2), $0 \leq \Psi \leq \pi/2$.

This formulation leads to a maximum reduction at an angle of 90° ($\Psi = \pi/2$) of -4.5 dB for category 1 and of -3 dB for category 2 and 3.

For low frequencies, deviating behaviour can be expected due to interference effects, but for L_{Aeq} estimation this effect can be neglected.

No directivity effect is defined for category 4 (two-wheelers) vehicles.

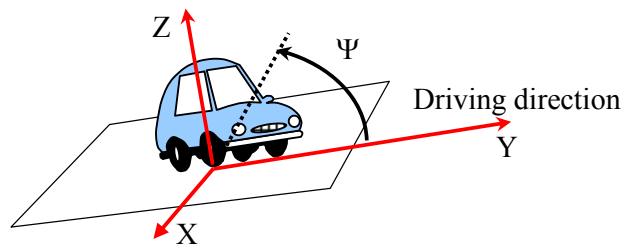

Figure II.4 - Geometry for the horizontal and vertical directivity functions.

For more complex situations, and in particular for the calculation of maximum sound pressure levels (L_{Amax}), more advanced formulations of directivity correction including the horizontal directivity can be used as described in reference [7].

Simplified method

For the simplified version of CNOSSOS-EU, it is recommended to neglect the directivity correction and assume omni-directivity of the source.

II.3. Additional effects

II.3.1. General considerations for regional corrections

Actual noise levels at a certain location can be influenced by deviations in the local vehicle fleet or in the road environmental conditions with respect to the current European average on which are based the model coefficients stated above. It is possible to take into account vehicle fleet variations, either to address regional or national variations, variations in time, or for action planning purposes, by introducing correction coefficient in the source model. Each correction is zero by default, meaning that if they are not applied, the results conform to the European average.

To allow a fair comparison between noise maps from various Member States, the regional specificities introduced to calculate the sound levels should be clearly indicated in the reporting phase.

The regional corrections are summarised in the Table II.2 below, in which the type of source affected is indicated in the second column and the name of the indicator for the correction in the third column.

Most of the regional corrections should be applied to the propulsion noise or rolling noise part only, before calculating the noise emission at the relevant source height. Some of them apply to specific categories of vehicles only. However, these corrections are intended for variations in a large vehicle fleet, therefore, they are expressed in a way they can be applied to an entire traffic flow of the relevant category.

Table II.2 – List of regional corrections

Regional effect	Source affected	Correction	Categories of vehicles	Described in section
Air temperature	Rolling noise	$\Delta L_{WR,temp}$	All cat. (except cat.4)	II.3.2.a
Wetness of the road surface	Rolling noise	$\Delta L_{WR,wet}$	cat.1	II.3.2.b
Truck with multi-axle and tyre mounting	Rolling noise	$\Delta L_{WR,2tyr}$ $\Delta L_{WR,axle}$	cat.3	II.3.3.a
Vehicle weight / Tyre width	Rolling noise	$\Delta L_{WR,wid}$	cat.1	II.3.3.b
Vehicles with studded tyres	Rolling noise	$\Delta L_{WR,stud}$	cat.1	II.3.3.c
Proportion of delivery vans	Rolling noise + Propulsion noise	$\Delta L_{WR,vans}$ $\Delta L_{WP,vans}$	cat.1	II.3.3.d
Engine fuel	Propulsion noise	$\Delta L_{WP,diesel}$	cat.1	II.3.3.e
Trucks with High exhaust systems	Additional point source	No correction	cat.3	II.1.2

Simplified method	It is recommended to omit regional specificities in the simplified version of CNOSSOS-EU, with the exception of temperature correction on rolling noise.
-------------------	--

II.3.2. Correction for regional road conditions and environment

II.3.2.a. Air temperature effect on rolling noise

It is generally accepted that the air temperature affects rolling noise emission: rolling sound power level decreases when the air temperature increases. The rolling sound power at an actual air temperature τ in °C can be expressed from the rolling sound power at the reference condition $\tau_{ref}=20^{\circ}\text{C}$ [2] by adding an overall corrective term $\Delta L_{WR,temp}$ given by:

$$\Delta L_{WR,temp} = K \times (20 - \tau) \quad (II-21)$$

The corrective term is positive (i.e. noise increases) for temperatures lower than 20 °C, and negative (i.e. noise decreases) for higher temperatures. The coefficient K depends on the road surface and the tyre characteristics. For simplified noise calculation, a generic coefficient $K = 0.08 \text{ dB}/^{\circ}\text{C}$ can be applied for all road surfaces. For more accurate calculation, a semi generic estimation for different characteristics of road surfaces is listed in Appendix II-B. It ranges between 0.03 and 0.12. The equation (II-21) is valid for air temperatures ranging from 5°C to 35°C.

Heavy duty vehicles are assumed to exhibit a lower temperature effect on rolling noise. The coefficients K for categories 2 and 3 are therefore taken to be half the value of those for category 1, as indicated in Appendix II-B.

Although K exhibits in general some frequency dependence, the correction coefficients proposed in this method apply to overall A-weighted noise levels.

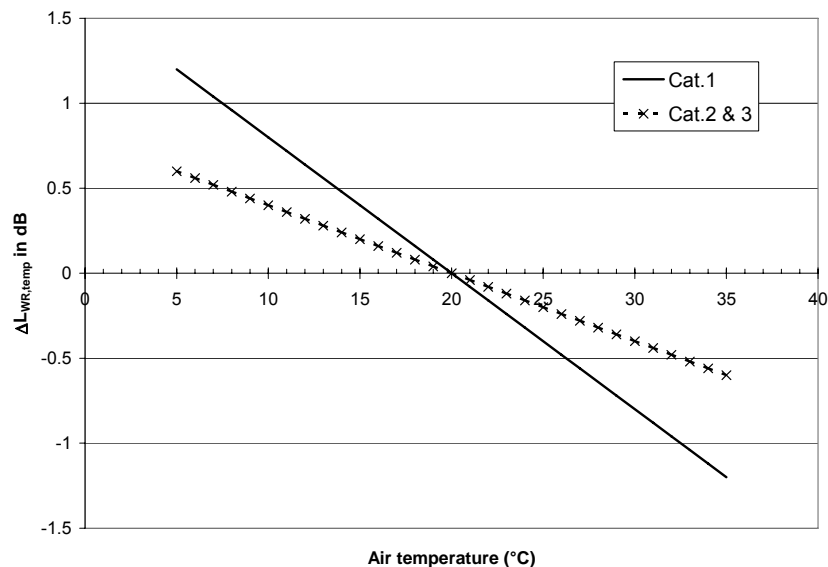

Figure II.5: Semi generic temperature correction.

Simplified method

It may be relevant to introduce this temperature correction in the simplified version of CNOSSOS-EU. The input data should then be the yearly averaged temperature, possibly distinguishing between day and night periods (to be described in the Guidance for the Competent Use of CNOSSOS-EU). The generic coefficient $K = 0.08 \text{ dB(A)}/^{\circ}\text{C}$ is recommended to be used.

II.3.2.b. Wetness of road surface

Vehicles on a wet surface emit higher rolling noise levels than on the same dry surface. This effect is relevant for category 1 vehicles but no significant effect was found for Category 2 and 3. Although the effect on dense surfaces has a different nature than the effect on porous surfaces, the increase of rolling noise emission on any wet surface for Category 1 vehicles, is taken into account by the following formula, that also accounts for the percentage of time occurrence of rain periods ($p\%$) :

$$\Delta L_{WR,wet} = \max \{ (15 \times \lg(f/f_0) - 12 \times \lg(v/v_{ref}) - 48); 0 \} \times (p\%/100\%) \quad (II-22)$$

with f the centre frequency of a 1/3-octave band, $f_0 = 1$ Hz, and v the speed of the vehicle.

The correction is only valid for periods when a film of water is present on the road surface (for example 2 mm thick water layer). Therefore it is of interest only in places where the rain periods cover a significant period ($p\% > 20\%$) over the year.

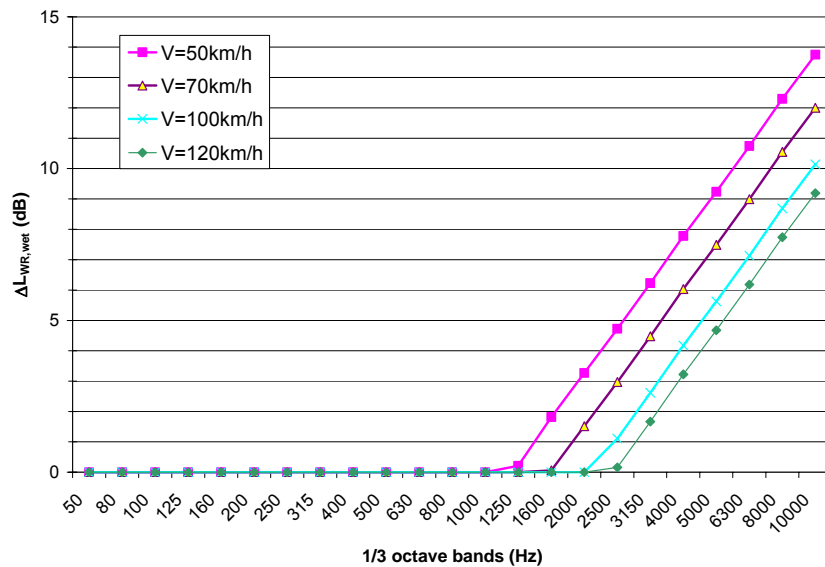

Figure II.6: Correction for wetness of road surface.

II.3.3. Correction for fleet regional specificities

II.3.3.a. Truck tyre mounting

For Category 3 vehicles, a default axle configuration of four axles is assumed: one steer axle with two single tyres, one driven axle with four single block tyres, and two trailer axles with two super-single trailer tyres each (10 tyres in total). The truck fleet may substantially differ from this reference condition. In this case, the application of correction factors can be applied, for the proportion of trucks having specific tyre-mounting configurations.

For trucks equipped with trailer axles carrying double mounted “steer axle”-type tyres, a slight increase of rolling noise is observed [9]:

$$\Delta L_{WR,2tyr} = p_t \times 0.8 \text{ dB} \quad (II-23)$$

Where p_t is the proportion of trucks equipped with trailer axles carrying double mounted “steer axle”-type tyres.

For trucks with a total number of axles N_{axles} different from the default value of 4, a correction $\Delta L_{WR,axle}$ (in dB) may be used:

$$\Delta L_{WR,axle} = p_a \times \begin{cases} 6.8 \times \lg\left(\frac{N_{axles}}{4}\right) & \text{for super - single tyres} \\ 9.1 \times \lg\left(\frac{N_{axles}}{4}\right) & \text{for double - mounted tyres} \end{cases} \quad (II-24)$$

Where p_a is the proportion of trucks equipped with N_{axles}

II.3.3.b. Vehicle weight and tyre width

The increase of rolling noise with tyre width for passenger cars was found to be 2 dB(A) between a 155 mm tyre from 1970 and a 195 mm tyre from 2000, or 0.5 dB(A) per 10 mm width increase [12]. On a series of modern passenger car tyres, an increase of 0.36 dB(A) per 10 mm increase of tyre width was found. Therefore, the following correction is proposed for passenger car tyres:

$$\Delta L_{WR,wid} = 0.04 \times (W_t - 187) \quad (II-25)$$

where W_t is the average tyre width of the fleet in mm

If no tyre width statistical data are found, the following relation between vehicle weight W_v and tyre width W_t , for passenger cars, can be used:

$$W_t \approx 0.062 \times W_v + 118 \text{ mm.} \quad (II-26)$$

For truck tyres, no correction is proposed; statistical variations of truck tyre widths over different regions are assumed negligible.

II.3.3.c. Studded tyres

In some EU countries, the use of studded tyres on passenger cars is common in winter time. The influence of studded tyres on the rolling noise L_{WR} for category 1 vehicles can be accounted for, by using a correction $\Delta L_{WR,stud}$ (in dB). This speed-dependant correction is taken from the interim model for Nordic countries [10], and is given by:

$$\Delta L_{WR,stud} = p_s \times \begin{cases} a + b \times \lg(v/70) & \text{for } 50 \leq v \leq 90 \text{ km/h} \\ a + b \times \lg(90/70) & \text{for } v > 90 \text{ km/h} \\ a + b \times \lg(50/70) & \text{for } v < 50 \text{ km/h} \end{cases} \quad (II-27)$$

where coefficients a and b are given for each 1/3-octave band in Appendix II-D, and p_s is the proportion of vehicles with studded tyres.

Studded tyres for trucks are not very common, though they may exist. Therefore, no correction is introduced in this method.

II.3.3.d. Delivery vans

Vehicle category 1 contains mostly passenger cars, but a certain amount of delivery vans (≤ 3500 kg) can also be present. The amount of delivery vans within this category varies significantly across Europe, but in some cases, their proportion in the traffic can be high. As it is recognised that the acoustic emission of such vehicles is on average notably higher than for passenger cars, the effect on the total noise emission can be significant. The average Category 1 delivery van is assumed to have 5 dB(A) more propulsion noise and 1 dB(A) more rolling noise than a passenger car. The effect of a percentage of delivery vans within the total number of light motor vehicles ($\%vans$), is taken into account by a linear correction applied to both noise sources given respectively in equations (II-28) and (II-29). This correction applies to the Category 1 traffic flow.

$$\Delta L_{WP,vans} = 5.0 \times \frac{\%vans - 10.5\%}{100\%} \quad (II-28)$$

$$\Delta L_{WR,vans} = 1.0 \times \frac{\%vans - 10.5\%}{100\%} \quad (II-29)$$

II.3.3.e. Engine fuel

For Category 1 vehicles, a distinction can be made between Diesel engines and other engines, the latter of which contains petrol, LPG, and other engine fuel types. Diesel engines tend to be noisier than other engines, though the difference is growing smaller with time. Type approval tests currently have a 1 dB(A) higher limit value for Diesel cars. An effect of +3 dB(A) on the propulsion noise of a single vehicle was observed experimentally [13]. Due to the substantial presence of rolling noise above 20 km/h, the effect on overall noise will be smaller and will decrease further with increasing vehicle speed.

The propulsion noise emission L_{WP} of the average Category 1 vehicle can be corrected for the local or national percentage of Diesel engines ($\%diesel$), with respect to the total number of light motor vehicles, using the following linear $L_{WP,diesel}$ correction that applied to the Category 1 traffic flow:

$$\Delta L_{WP,diesel} = 3.0 \times \frac{\%diesel - 19\%}{100\%} \quad (II-30)$$

II.3.4. Correction for structural radiation (bridges and viaducts)

There is currently only limited knowledge on the prediction of the effect of structural radiation from bridges and viaducts [14]. Bridges and viaducts can be treated in a case dependent study, by considering the specifics of sound propagation due to the geometry around the structure. Methods described in Chapter V “Sound propagation” of this present method can be used. However, it should be noted that in this case, only sound propagation is addressed, but not the structural radiation. Alternatively, more complex methods such as BEM can be used, in which structural radiation can possibly be introduced.

In other cases, no correction should be applied.

II.3.5. Correction for tunnel openings

Tunnel openings should be calculated by introducing a reflective plane exactly at the entrance of the tunnel to account for the increase in the noise coming out of the tunnel. In the case where the tunnel opening is treated acoustically with absorbing material, the reflecting plane must be replaced by an absorbing plane. Details of calculations can be found in Chapter V on “*Sound propagation*” of this report.

References

- [1] R. Nota et al., *Engineering method for road traffic and railway noise after validation and fine-tuning*, EU-FP5 project “HARMONOISE” deliverable report n°D18 (HAR32TR-040922-DGMR20), DGMR, 2005.
- [2] B. Peeters et al., *The Noise Emission Model For European Road Traffic*, EU-FP6 project “IMAGINE” deliverable report n°D11 (IMA55TR-060821-MP10), M+P, 2007.
- [3] H.G. Jonasson, *Acoustical Source Modelling of Road Vehicles*, Acta Acustica United with Acustica, Vol. 93(2), p 173 - 184, 2007.
- [4] *Guidelines for the use of traffic models for noise mapping and noise action planning*, EU-FP6 project “IMAGINE” deliverable report n° 7 (IMA02DR7-060531-TNO10), TNO, 2006.
- [5] *Review of the suitability of traffic models for noise modelling*, EU-FP6 project “IMAGINE” report (IMA02TR-050112-TML10), TML, 2005.
- [6] *Guidance manual for the implementation of low-noise road surfaces*, EU-FP5 project “SILVIA” final report, FEHRL, Bruxelles, 2006.
- [7] H. Jonasson et al., *Source modeling of road vehicles*, EU-FP5 project “HARMONOISE” deliverable report n°D09 (HAR11TR-041210-SP10), SP, 2004.
- [8] *Prévision du bruit routier – Partie 1: Calcul des émissions sonores dues au trafic routier*, Guide méthodologique SETRA, 2009.
- [9] R. van Moppes, *Spectral analysis of noise measurements on truck tyres*, EU-FP6 project “IMAGINE” report (IMA53TR-060512-MP11), M+P, 2006.
- [10] H. Jonasson, *Acoustic Source Modelling of Nordic Road Vehicles*, SP Rapport 2006:12, final revision, Borås (SE), 2006.
- [11] U. Sandberg, J.A. Ejsmont, “Tyre/Road Noise Reference book”, 1st Edition, Informex, Kisa (SE), 2002.
- [12] B. Andersen, H. Bendtsen, *Noise emission from 4000 vehicle pass-bys*, Proc. Internoise 2004, Prague, 2004;
- [13] S. Sakamoto, A. Fukushima, K. Yamamoto, *Road traffic noise prediction model “ASJ RTN-Model 2008” proposed by the Acoustical Society of Japan - Part 3: Calculation model of sound propagation*, Proc. Inter-Noise 2009, Ottawa, Canada, 2009.

APPENDIX II-A - Table of coefficients for sound power emission of road vehicles

The tables below give the coefficients necessary for the calculation of:

- the rolling noise as defined in equation (II-6) (coefficients A_R and B_R)

$$L_{WR} = A_R + B_R \times \lg\left(\frac{v}{v_{ref}}\right) + \Delta L_{WR,road} + \Delta L_{WR,region} \quad (II-6)$$

- the propulsion noise as defined in equation (II-8) (coefficients A_P and B_P)

$$L_{WP} = A_P + B_P \times \frac{(v - v_{ref})}{v_{ref}} + \Delta L_{WP,road} + \Delta L_{WP,region} \quad (II-8)$$

- and the correction on propulsion noise due to acceleration, as defined in equation (II-10) (coefficient C_P)

$$\Delta L_{WP,acc} = \begin{cases} C_P \cdot a & \text{for } a \geq -1 \text{ m/s}^2 \\ C_P \cdot (-1) & \text{for } a < -1 \text{ m/s}^2 \end{cases} \quad \text{with } |a| \leq a_{max} \quad (II-10)$$

Table II.A.1 – Table of coefficient for **category 1** vehicles (passenger cars)

1/3 octave band center freq. (Hz)	A_R	B_R	A_P	B_P	C_P
25	69.9	33.0	87.0	0.0	4.0
31.5	69.9	33.0	87.0	0.0	4.0
40	69.9	33.0	87.0	0.0	4.0
50	74.9	30.0	87.9	0.0	7.0
63	74.9	30.0	90.8	-3.0	7.0
80	74.9	30.0	89.9	0.0	7.0
100	79.3	41.0	86.9	8.0	7.0
125	82.0	41.2	82.6	6.0	7.0
160	81.2	42.3	81.9	6.0	7.0
200	80.9	41.8	82.3	7.0	7.0
250	78.9	38.6	83.9	8.0	4.0
315	78.8	35.5	83.3	8.0	4.0
400	80.5	32.9	82.4	8.0	4.0
500	85.0	25.0	80.6	8.0	4.0
630	87.9	25.0	80.2	8.0	4.0
800	90.9	27.0	77.8	8.0	4.0
1000	93.3	33.4	78.0	8.0	4.0
1250	92.8	36.7	81.4	8.0	4.0
1600	91.5	37.0	82.3	8.0	4.0
2000	88.5	37.5	82.6	8.0	4.0
2500	84.9	37.5	81.5	8.0	4.0
3150	81.8	38.6	80.2	8.0	4.0
4000	78.7	39.6	78.5	8.0	4.0
5000	74.9	40.0	75.6	8.0	4.0
6300	71.8	39.9	73.3	8.0	4.0
8000	69.1	40.2	71.0	8.0	4.0
10000	65.6	40.3	68.1	8.0	4.0

Table II.A.2 – Table of coefficient for **category 2** vehicles (medium heavy vehicles)

1/3 octave band center freq. (Hz)	A_R	B_R	A_P	B_P	C_P
25	76.5	33.0	93.9	0.0	5.0
31.5	76.5	33.0	93.9	0.0	5.0
40	76.5	33.0	94.1	0.0	5.0
50	78.5	30.0	95.0	0.0	9.0
63	79.5	30.0	97.3	-4.0	9.0
80	79.5	30.0	96.1	0.0	9.0
100	82.5	32.9	92.5	4.0	9.0
125	84.3	35.9	91.9	5.0	9.0
160	84.7	38.1	90.4	5.5	9.0
200	84.3	36.5	93.4	6.0	9.0
250	87.4	33.5	94.4	6.5	5.0
315	87.8	30.6	94.2	6.5	5.0
400	89.8	27.7	93.0	6.5	5.0
500	91.6	21.9	90.8	6.5	5.0
630	93.5	23.8	92.1	6.5	5.0
800	94.6	28.4	92.5	6.5	5.0
1000	92.4	31.1	94.1	6.5	5.0
1250	89.6	35.4	94.5	6.5	5.0
1600	88.1	35.9	92.4	6.5	5.0
2000	85.9	36.7	90.1	6.5	5.0
2500	82.7	36.3	87.6	6.5	5.0
3150	80.7	37.7	85.8	6.5	5.0
4000	78.8	38.5	83.8	6.5	5.0
5000	76.8	39.8	81.4	6.5	5.0
6300	76.7	39.9	80.0	6.5	5.0
8000	75.7	40.2	77.2	6.5	5.0
10000	74.5	40.3	75.4	6.5	5.0

Table II.A.3 – Table of coefficient for **category 3** vehicles (heavy duty vehicles)

1/3 octave band center freq. (Hz)	A_R	B_R	A_P	B_P	C_P
25	79.5	33.0	95.7	0.0	5.0
31.5	79.5	33.0	94.9	0.0	5.0
40	79.5	33.0	94.1	0.0	5.0
50	81.5	30.0	96.8	-4.0	9.0
63	82.5	30.0	101.8	0.0	9.0
80	82.5	30.0	98.6	4.0	9.0
100	85.5	31.4	95.5	3.0	9.0
125	87.3	32.8	96.2	3.0	9.0
160	87.7	36.0	95.7	3.0	9.0
200	87.3	34.6	97.2	4.0	9.0
250	89.5	32.7	96.3	5.0	5.0
315	90.5	29.3	97.2	5.0	5.0
400	93.8	26.4	95.8	5.0	5.0
500	95.9	24.2	95.9	5.0	5.0
630	97.3	25.9	96.8	5.0	5.0
800	98.0	30.4	95.1	5.0	5.0
1000	95.6	32.3	95.8	5.0	5.0
1250	93.2	36.5	95.0	5.0	5.0
1600	91.9	36.8	92.7	5.0	5.0
2000	88.9	38.0	91.2	5.0	5.0
2500	85.5	36.8	88.7	5.0	5.0
3150	84.1	38.5	87.6	5.0	5.0
4000	82.2	38.9	87.2	5.0	5.0
5000	79.8	38.5	84.2	5.0	5.0
6300	78.6	40.2	82.7	5.0	5.0
8000	77.5	40.8	79.7	5.0	5.0
10000	76.8	41.0	77.6	5.0	5.0

Table II.A.4 – Table of coefficient for **category 4a** vehicles (Powered 2-wheelers ≤ 50 cc)

1/3 octave band center freq. (Hz)	A_R	B_R	A_P	B_P	C_P
25	0.0	0.0	88.7	-2.2	4.0
31.5	0.0	0.0	87.6	-0.1	4.0
40	0.0	0.0	85.5	1.7	4.0
50	0.0	0.0	85.8	5.9	7.0
63	0.0	0.0	81.5	1.9	7.0
80	0.0	0.0	80.7	3.3	7.0
100	0.0	0.0	82.0	0.9	7.0
125	0.0	0.0	85.6	17.3	7.0
160	0.0	0.0	81.6	14.5	7.0
200	0.0	0.0	81.4	5.0	7.0
250	0.0	0.0	85.5	14.6	4.0
315	0.0	0.0	86.3	9.9	4.0
400	0.0	0.0	87.9	9.7	4.0
500	0.0	0.0	88.7	12.7	4.0
630	0.0	0.0	89.9	12.3	4.0
800	0.0	0.0	91.8	13.9	4.0
1000	0.0	0.0	91.2	16.6	4.0
1250	0.0	0.0	92.4	17.2	4.0
1600	0.0	0.0	95.0	17.9	4.0
2000	0.0	0.0	94.1	19.3	4.0
2500	0.0	0.0	92.9	20.6	4.0
3150	0.0	0.0	90.4	19.9	4.0
4000	0.0	0.0	89.1	20.8	4.0
5000	0.0	0.0	87.4	20.5	4.0
6300	0.0	0.0	84.9	21.0	4.0
8000	0.0	0.0	84.4	21.0	4.0
10000	0.0	0.0	82.2	19.3	4.0

Table II.A.5 – Table of coefficient for **category 4b** vehicles (Powered 2-wheelers > 50 cc)

1/3 octave band center freq. (Hz)	A_R	B_R	A_P	B_P	C_P
25	0.0	0.0	90.8	2.1	4.0
31.5	0.0	0.0	88.9	3.1	4.0
40	0.0	0.0	89.2	1.2	4.0
50	0.0	0.0	90.5	2.3	7.0
63	0.0	0.0	89.2	2.8	7.0
80	0.0	0.0	90.7	4.2	7.0
100	0.0	0.0	93.2	6.2	7.0
125	0.0	0.0	93.2	4.8	7.0
160	0.0	0.0	90.0	7.3	7.0
200	0.0	0.0	88.4	11.3	7.0
250	0.0	0.0	87.6	10.6	4.0
315	0.0	0.0	87.7	13.9	4.0
400	0.0	0.0	87.0	13.5	4.0
500	0.0	0.0	87.4	11.0	4.0
630	0.0	0.0	89.4	10.8	4.0
800	0.0	0.0	89.9	11.4	4.0
1000	0.0	0.0	90.1	11.4	4.0
1250	0.0	0.0	89.7	11.7	4.0
1600	0.0	0.0	89.8	13.4	4.0
2000	0.0	0.0	88.2	11.6	4.0
2500	0.0	0.0	86.5	12.2	4.0
3150	0.0	0.0	85.8	10.9	4.0
4000	0.0	0.0	85.1	10.5	4.0
5000	0.0	0.0	85.1	12.0	4.0
6300	0.0	0.0	82.7	12.0	4.0
8000	0.0	0.0	81.7	12.0	4.0
10000	0.0	0.0	80.4	12.0	4.0

APPENDIX II-B - Correction coefficients for air temperature effect on rolling noise

Table II.B.1 – Semi-generic correction coefficients K in dB/°C for air temperature on rolling noise emission, according to the texture and the open porosity of the road surface layer – For Category 1 vehicles

category 1 vehicles (light motor vehicles)	Porosity class (Ω)		
Texture class (MPD⁽¹⁾)	$\Omega \leq 5\%$	$5\% < \Omega < 15\%$	$\Omega \geq 15\%$
MPD ≤ 0.5 mm	0.04	0.06	0.08
0.5 mm < MPD < 1.5 mm	0.08	0.07	0.06
MPD ≥ 1.5 mm	0.12	0.08	0.03

⁽¹⁾ MPD: Mean Profile Depth

Table II.B.2 – Semi-generic correction coefficients K in dB/°C for air temperature on rolling noise emission, according to the texture and the open porosity of the road surface layer – For Category 2 and 3 vehicles

category 2 and 3 vehicles (heavy motor vehicles)	Porosity class (Ω)		
Texture class (MPD⁽¹⁾)	$\Omega \leq 5\%$	$5\% < \Omega < 15\%$	$\Omega \geq 15\%$
MPD ≤ 0.5 mm	0.02	0.03	0.04
0.5 mm < MPD < 1.5 mm	0.04	0.04	0.03
MPD ≥ 1.5 mm	0.06	0.04	0.02

For updated figures Refer to ISO TC43 WG 27 and related ISO/CD 13471-1 draft documents.

APPENDIX II-C - Examples of correction coefficients for road surface effect on rolling noise

• REFERENCE SURFACE

A “reference cluster” of Dense Asphalt Concrete (DAC) and Stone Mastic Asphalt (SMA) surfaces was set during the HARMONOISE and the IMAGINE research projects [1] [2], among which the virtual reference road surface was defined: this virtual road surface consists of a mixture of DAC 0/11 and SMA 0/11 between 2 and 7 years and in a representative maintenance condition.

For other surfaces within this reference cluster, i.e. belonging to the same “reference” types of surfaces, it is possible to correct the reference level according to the maximum chipping size of the dense surface. The following correction $\Delta L_{WR,road}$ in dB can be applied:

- for light motor vehicles (Cat. 1):

$$\begin{aligned} \circ \text{ DAC: } \Delta L_{WR,road} &= -0.3 + 0.25 \times \frac{D-11}{D_0} \\ \circ \text{ SMA: } \Delta L_{WR,road} &= +0.3 + 0.25 \times \frac{D-11}{D_0} \end{aligned} \quad (II-C-1)$$

where D is the maximum chipping size in mm, $8 \text{ mm} \leq D \leq 16 \text{ mm}$, and $D_0 = 1 \text{ mm}$. The correction is frequency and speed independent. It is applied equally to the coefficient A_R for each frequency band.

- for heavy and medium heavy vehicles (Cat. 2 and 3): no correction is applied for surfaces within the reference cluster.

• OTHER SURFACES

For other road surfaces, the correction on the rolling noise level is given by equation (II-C-2):

$$\Delta L_{WR,road} = \alpha_{i,m} + \beta_m \times \lg\left(\frac{v}{v_{ref}}\right) \quad (II-C-2)$$

where : $\alpha_{i,m}$ is the spectral correction in dB at reference speed $v_{ref} = 70 \text{ km/h}$ for category m (1, 2 or 3) and spectral band i (1/3-octave bands from 50 to 10000 Hz).

β_m is the speed effect on rolling noise reduction.

Some examples of numerical values obtained on a large set of road surfaces in the Netherlands [1] are given in Table II-C-1 below. It is noted that correction factors for Porous Asphalts are valid for a modelling of sound propagation over a non-porous road surface. The propagation effect is included in the noise emission correction factors.

Table II-C-1 – Road surface correction coefficients for light motor vehicles (Cat.1) (Dutch database [2])

category 1		transversely brushed concrete	concrete with surface dressing 2/4	exposed aggregate concrete	PA ⁽¹⁾ 6/16	2-layer PA ⁽¹⁾ 4/8-11/16	SMA ⁽²⁾ 0/6	surface dressing 4/8
$\alpha_{i,1}$	50 Hz	0.0	0.0	0.0	0.0	0.0	0.0	0.0
	63Hz	0.0	0.0	0.0	0.0	0.0	0.0	0.0
	80 Hz	0.0	0.0	0.0	0.0	0.0	0.0	0.0
	100 Hz	0.0	0.0	0.0	0.0	0.0	0.0	0.0
	125 Hz	0.0	0.0	0.0	0.0	0.0	0.0	0.0
	160 Hz	0.9	0.7	0.3	0.0	-0.5	0.0	1.7
	200 Hz	1.7	1.4	0.7	0.0	-1.1	0.0	3.4
	250 Hz	2.6	2.1	1.0	0.0	-1.6	0.0	5.1
	315 Hz	2.5	2.4	1.1	0.0	-2.2	0.0	5.3
	400 Hz	2.5	2.7	1.1	0.0	-2.7	0.0	5.4
	500 Hz	2.4	3.0	1.2	0.0	-3.3	0.0	5.6
	630 Hz	2.0	3.2	1.4	-0.4	-3.6	-0.7	5.3
	800 Hz	1.6	3.3	1.7	-0.7	-4.0	-1.3	4.9
	1 kHz	1.2	3.5	1.9	-1.1	-4.3	-2.0	4.6
	1.25 kHz	1.6	2.4	1.5	-2.2	-5.2	-2.3	2.6
	1.6 kHz	2.0	1.2	1.2	-3.4	-6.0	-2.6	0.5
	2 kHz	2.4	0.1	0.8	-4.5	-6.9	-2.9	-1.5
	2.5 kHz	1.6	-0.2	0.5	-4.8	-6.8	-2.7	-1.8
	3.15 kHz	0.8	-0.5	0.3	-5.0	-6.8	-2.4	-2.2
	4 kHz	0.0	-0.8	0.0	-5.3	-6.7	-2.2	-2.5
5 kHz	0.0	-0.5	0.0	-3.5	-4.5	-1.5	-1.7	
6.3 kHz	0.0	-0.3	0.0	-1.8	-2.2	-0.7	-0.8	
8 kHz	0.0	0.0	0.0	0.0	0.0	0.0	0.0	
10 kHz	0.0	0.0	0.0	0.0	0.0	0.0	0.0	
speed index (β_1)		6.0	-5.0	0.0	-11.0	-6.0	-5.0	-4.0
A-weighted correction at 70 km/h		1.4	2.7	1.3	-1.4	-4.6	-1.7	3.4

⁽¹⁾ PA: Porous Asphalt

⁽²⁾ SMA: Stone Mastic Asphalt

Table II-C-2 – Road surface correction coefficients for heavy motor vehicles (Cat.2 and 3) (Dutch database [2])

category 1		transversely brushed concrete	concrete with surface dressing 2/4	exposed aggregate concrete	PAC ⁽¹⁾ 6/16	2-layer PAC ⁽¹⁾ 4/8-11/16	SMA ⁽²⁾ 0/6	surface dressing 4/8
$\alpha_{i,2}$, $\alpha_{i,3}$	50 Hz	0	0	0	0	0	0	0
	63Hz	0	0	0	0	0	0	0
	80 Hz	0	0	0	0	0	0	0
	100 Hz	0	0	0	0	0	0	0
	125 Hz	0	0	0	0	0	0	0
	160 Hz	0.7	0.4	0.0	0.3	-0.1	0.0	0.8
	200 Hz	1.5	0.7	0.0	0.7	-0.2	0.0	1.7
	250 Hz	2.2	1.1	0	1	-0.3	0	2.5
	315 Hz	2.0	1.0	-0.1	-0.7	-2.1	-0.2	1.8
	400 Hz	1.9	0.9	-0.1	-2.5	-3.9	-0.4	1.1
	500 Hz	1.7	0.8	-0.2	-4.2	-5.7	-0.6	0.4
	630 Hz	1.6	0.2	-0.4	-4.3	-6.1	-0.9	-0.1
	800 Hz	1.4	-0.3	-0.6	-4.4	-6.5	-1.3	-0.5
	1 kHz	1.3	-0.9	-0.8	-4.5	-6.9	-1.6	-1
	1.25 kHz	0.9	-1.3	-1.0	-4.1	-6.4	-1.5	-1.3
	1.6 kHz	0.6	-1.6	-1.3	-3.7	-6.0	-1.3	-1.5
	2 kHz	0.2	-2	-1.5	-3.3	-5.5	-1.2	-1.8
	2.5 kHz	-0.3	-2.0	-1.6	-3.1	-5.1	-1.2	-1.9
	3.15 kHz	-0.8	-2.0	-1.8	-2.8	-4.8	-1.1	-2.0
	4 kHz	-1.3	-2	-1.9	-2.6	-4.4	-1.1	-2.1
5 kHz	-0.9	-1.3	-1.3	-1.7	-2.9	-0.7	-1.4	
6.3 kHz	-0.4	-0.7	-0.6	-0.9	-1.5	-0.4	-0.7	
8 kHz	0	0	0	0	0	0	0	
10 kHz	0	0	0	0	0	0	0	
<i>speed index (β_2, β_3)</i>		12	5	15	-6	-8	0	13
A-weighted correction at 70 km/h		1.1	-0.6	-0.8	-3.8	-5.8	-1.1	-0.7

APPENDIX II-D - Coefficients for studded tyres effect on rolling noise emission - Light motor vehicles (Cat.1)

Table II-D – Coefficients a and b for studded tyres correction $\Delta L_{WR,stud} = a + b \cdot \lg(v/70)$, for category 1 vehicles only

1/3-octave band frequency [Hz]	a	b
25	0	0
31.5	0	0
40	0	0
50	0	0
63	0	0
80	0	0
100	0	0
125	0.3	-4.1
160	1.4	-6
200	1.5	-8.5
250	0.9	-4.1
315	1.2	1.7
400	1.5	0.6
500	1.9	-4.6
630	1.8	-3.9
800	0.8	-2.7
1000	0.5	-4.2
1250	0.2	-11.7
1600	-0.2	-11.7
2000	-0.4	-14.9
2500	0.5	-17.6
3150	0.8	-21.8
4000	0.9	-21.6
5000	2.1	-19.2
6300	5	-14.6
8000	7.3	-9.9
10000	10	-10.2

CHAPTER III. RAILWAY NOISE SOURCE EMISSION

III.1. Source description

III.1.1. Classification of vehicles

The relevant sound sources contributing to the generation and radiation of railway noise and tram noise consist of various components of the track-train system, namely: the rails and the sleeper or slab, the wheels, the fans, the compressors and the engines, the electrical equipment and the exhaust in the case of diesel-powered locomotives and the superstructure of freight trains. At high speeds, aerodynamics of the bogies and of the pantograph and the train body become relevant as well. Depending on the speed, contributions from these sources change their relative importance, therefore it is not possible to exclude a priori any of these sources. The sources mentioned are mostly dependent on the specific features of single sub-units within a train, rather than being of constant type along the whole train. For this reason, it is appropriate to classify each single sub-unit of a train, and add up the number of single sub-units travelling on a specific track section, rather than using classifications by the whole train type.

Definition of vehicle and train

For the purposes of this noise calculation method, a **vehicle** is defined as any single railway sub-unit of a train (typically a locomotive, a self-propelled coach, a hauled coach or a freight wagon) that can be moved independently and can be detached from the rest of the train. Some specific circumstances may occur for sub-units of a train that are a part of a non-detachable set, e.g. share one bogie between them. For the purpose of this calculation method, all these sub-units are grouped into a single vehicle. Further explanation is given under “Remarks on digit 2 and 3”.

For the purpose of this calculation method, a **train** consists of a series of coupled vehicles.

In the Table III-1a the descriptor used to classify the vehicles reflects only the common commercial classification of the train, and it is to be used for a simplified approach. Table III-1b presents instead the relevant parameters to be used to classify in full the vehicles through their significant acoustic parameters. These descriptors correspond to properties of the vehicle which affect the acoustic sound power per metre length of the equivalent sound source modelled.

The number of vehicles for each type shall be determined on each of the track sections for each of the time periods to be used in the noise calculation. It shall be expressed as an average number of vehicles per second that is obtained by dividing the total number of vehicles travelling in a given time period by the duration in seconds of such time period (e.g.: 24 vehicles in 4 hours means 0.0017 vehicles per second). All vehicle types travelling on each track section (defined in the next sub-chapter III.1.2) shall be used.

Depending on the available information, the classification of the vehicles might be more or less detailed. As a minimum, a classification drawn from 6 vehicle types following a general classification of type of train (or tram/metro) of which the vehicle is part (described by the digit 1) shall be used (commercial classification of trains), though subcategories of vehicle types classified according to the other digits are preferably to be used.

Table III-1a – Classification and descriptors for vehicles based on the classification of the whole train.

Digit:	1
Descriptor	Vehicle type
Explanation of the descriptor	The type of the train is used
Possible descriptors	L Loco
	H High speed passenger (>200 km/h)
	P Conventional Passenger
	F Freight
	T Tram or light metro
	O Other (i.e. maintenance vehicles...)

Table III-1b – Classification and descriptors for railway vehicles

Digit:	1	2	3	4	5	6
Descriptor	Number of axles per vehicle	Brake type	Vehicle type	Load	Wheel diameter	Wheel measure
Explanation of the descriptor	the actual number of axles	a letter that describes the brake type	a letter that describes the type	freight vehicle load	the class of diameter	a letter that describes the measure type
Possible descriptors	u unknown	u unknown	u unknown	u unknown	u unknown	n no measure
	1	c cast-iron block	h high speed vehicle (>200 km/h)	l loaded freight	l large, >800 mm	d dampers
	2	k composite or sinter metal block	M self-propelled passenger coaches	n not loaded freight	m medium, 500 to 800 mm	s screens
	3	n non tread braked, like disc, drum, magnetic	P hauled passenger coaches		s small < 500 mm	o other
	4		C City tram or light metro self-propelled and non self-propelled coach			
	et cetera		d diesel loco			
			e electric loco			
			a any generic freight vehicle			
		E, F, G, H, I, K, L, O, R, S, T, U, Z for specific freight vehicles according to UIC-designation for freight vehicles (see figure III-3)				

The parameters associated with the different vehicle types will be found in the CNOSSOS-EU database (still to be developed).

- Generally, if vehicle types are classified by using “u” for most descriptors, an uncertainty is introduced in the calculation since potentially acoustically different vehicles having different acoustic properties will be grouped under the same vehicle type, though eventually showing different sound contribution because of the differences due to those parameters which are left unknown, and can therefore differ.
- Simplifications can be used by means of grouping different vehicle types to avoid having too many different vehicle types to use in the calculation. Though this can speed up input data acquisition and calculations, it will in general introduce higher discrepancies between real and calculated noise levels.

Remarks on digit 1:

There are vehicle types that remain coupled during their lifetime.

- Many passenger trains consist of 2 or more elements that are never disconnected. These should be normally regarded as one single vehicle (also known as a “multiple unit” if self propelled). An example of a 3-element self-propelled passenger train (multiple units) is shown in figure III-1.

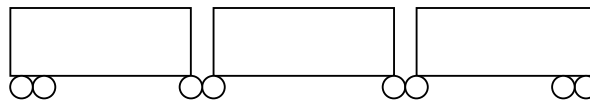

Figure III-1: three elements are coupled without the possibility of uncoupling them in normal conditions

- In cases of coupled elements, the number of axles can also be odd: e.g. if a common 2-axle bogie is shared by two coupled elements, the number of axles per vehicle (comprising two coupled elements as explained under the first bullet and in figure III-1) is 3.
- Some passenger trains, like that illustrated in figure III-1, have a fractional number of axles per vehicle if the train is not to be treated as a single vehicle. This train has 8 axles on 3 vehicles. In this case, the number should be rounded to the nearest whole number, i.e. $8/3 = 2.7 \sim 3$ axles per unit.
- Also, some freight wagon sets consist of 2 (or more) coupled elements that have one single UIC designation. An example is shown in figure III-2. As it is not always clear during way-side data collection whether a freight vehicle is part of a set or not, all freight wagon sets have to be considered as separate vehicles.

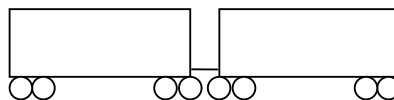

Figure III-2: two elements that are internationally classified as one single vehicle, but in fact behave acoustically as two separate vehicles

- In the case of calculations, if the number of axles is set unknown, four axles per vehicle shall be assumed.

Remarks on digit 2

The brake type is usually not clear from watching the trains passing by. Braking blocks, if visible, can be cast-iron, composite-blocks, sinter et cetera. Only by using a priori knowledge of the rolling stock can the braking type be identified. In the case of combinations of braking type on the same vehicle, the type that can be expected to affect the wheel tread most is considered dominant ('c' is dominant over 'k', and 'k' is dominant over 'n'). The brake type can also be estimated from measurement of sound or rail vibration and speed given that it is known that different brake types produce different roughness levels and therefore different vibrations and noise are expected.

Remarks on digit 3

Freight trains may take many forms. The first letter of the international UIC designation is used to classify the freight vehicles. The drawings in figure III-3 provide some assistance in their identification.

In the case of multiple unit passenger trains with powered and unpowered vehicles, m is used if the train is analysed as a whole. In the case where unpowered vehicles can be moved independently, p should be used while m is applied for those that are powered. For instance, in the above example of the 3-element train in figure III-1, the outer vehicles are motored and therefore named $3nMumn$, and therefore the whole train is also named $3nMumn$.

Remarks on digit 4

Container wagons are regarded as loaded if there is at least one container present. Even though a container may be empty, digit 5 is set to 1. This makes it possible to sort on empty flat wagons.

In many cases, it is not clear if a vehicle carries significant load: u is used in this case. Also use u for passenger coaches.

Remarks on digit 5

The wheel diameter for most passenger and freight trains is usually more than 800 mm (= 1 for "large"). Some flat container carriers and car carriers have smaller wheels. For passenger trains, some "light rail" vehicles may have smaller wheels.



		Digit 4: vehicle types	
	E Open wagon, standard design, 2 or 4 axle with side or end loading and flat floor (e.g. for coal, sand)		
	F Open wagon, non-standard design, 2 or 4 axle (e.g. mineral wagon, ballast wagon or hopper)		
	G Closed wagon (van), standard design (having 8 or more sliding doors) 2 or 4 axle	H Closed wagon (van), non-standard design (e.g. sliding walls) 2 or 4 axle	I Isolated or refrigerator wagon 2 or 4 axle
	K 2-axle flat wagon, standard design, with stakes and drop-down side walls	O 2-axle flat or open wagon, standard design with fixed side boards and stakes	
	L 2- or 3-axle flat wagon, non-standard design (e.g. some car carrier wagons)	S 4-axle (bogie) flat wagon, non-standard design	
	R 4-axle (bogie) flat wagon, standard design, with stakes and drop-down end boards (e.g. container wagon)		
T Wagon with opening roof			
U Other non-standard wagons			
	Z tank wagon (also with spherical silos)	<i>caution: some framed tanks are actually containers (R)!</i>	
h high speed vehicles			
m self-propelled vehicles			
p pulled vehicles			

Figure III-3 – Classification of common vehicle types.

Simplified method	In several situations, detailed information on the different types of vehicles is missing. In these situations, it is recommended to use a classification based only on the most common commercial grouping. In these cases, only the six vehicle categories of table III-1a is recommended to be used: L-Loco, H-High speed passenger, P-Conventional Passenger, F-Freight, C -tram or light metro, O-other types.
--------------------------	---

III.1.2. Classification of tracks and support structure

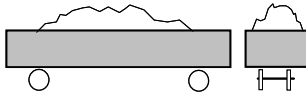
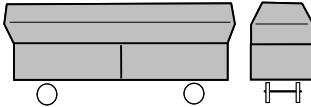
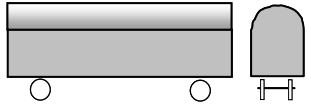
The existing tracks might differ because of several elements composing and characterising their acoustic properties, which are listed in table III-2 below. Some of the elements have a large influence on the acoustic properties, while some others have only secondary effect. The most relevant elements influencing the railway noise emission are: railhead roughness, rail pad stiffness, track base, rail type and radius of curvature of the track. Alternatively, the overall track properties can be defined and, in this case, the railhead roughness and the track decay rate according to ISO 3095 are the two acoustically essential parameters.

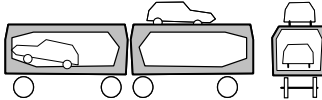
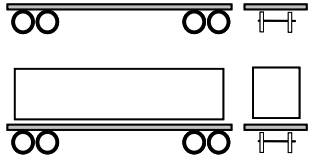
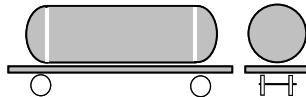
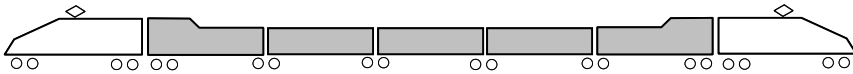
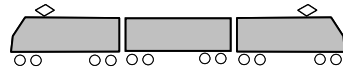
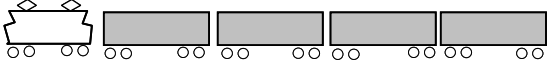
A track section is defined as a part of a single track, on a railway line or station or depot, on which the track physical properties and basic components do not change.

Table III-2 presents the relevant acoustic parameters to be used to classify the track types on each railway line section. Except for the first descriptor, which reflects only the common commercial classification of the railway lines, all other descriptors correspond to properties of the track section that affect the acoustic sound power per metre length of the equivalent sound source modelled.

Table III-2 – Classification of the track types.

Digit:	1	2	3	4	5	6	7	8	9	11	12
descriptor	Track base	Roughness	Rail pad type	Rail Fastener	Sleeper type	Rail type	Sleeper spacing	Additional measures	Rail joints	Curvature	Track dynamic characteristics
how it is encoded	Type of track base	Indicator for roughness	Presents an indication of the "acoustic" stiffness	Fastener abbreviation	Sleeper type indicator	kg/m	Distance in cm	A letter describing acoustic device	Presence of joints and spacing	Indicate the radius of curvature in m	Decay rates
Codes allowed	B Ballast	E Well maintained and very smooth	S Soft (150-250 MN/m)	S Single pad	W Wood	S (60 kg/m)	S standard (60 cm)	N none	N None	N straight track	U unknown
	S Slab track	M Normally maintained	M Medium (250 to 800 MN/m)	D Double pad	M Concrete mono-block	F (54 kg/m)	O other (specify cm)	D Rail damper	S Single joint or switch	L low (1000-500 m)	O (specify spectrum)
	C Concrete bridge	N Not well maintained	H Stiff (800-1000MN/m)	O Other	B Concrete bi-block	E Embedded rail		B Low barrier	D Two joints or switches per 100 m	M medium (less than 500 m and more than 200 m)	
	E Steel bridge	B Not maintained and bad condition			Z Steel zigzag	O other (specify kg/m)		A Absorber plate on slab track	M More than two joints or switches per 100 meter	H high (less than 200m)	
	T embedded track				S Steel			O Other			
	O Other										

Depending on the available information, the classification of the track sections might be more or less detailed.

The parameters associated with the different track section types will be found in the CNOSSOS-EU database (still to be developed).

- Generally, if track section types are classified by using “u” for most descriptors, an uncertainty is introduced in the calculation since potentially acoustically different track sections having different acoustic properties will be grouped under the same track section type, though eventually showing different sound contribution because of the differences due to those parameters which are left unknown, and can therefore differ.
- Simplifications can be used by means of grouping different track section types to avoid having too many different track section types to use in the calculation. Though this can speed up input data acquisition and calculations, it will generally introduce higher discrepancies between real and calculated noise levels.

Remarks on digit 2

The wave-number spectrum of the roughness is obtained according to the standard EN 15610:2009, measured in dB re 1 µm:

- shall be less than the spectrum defined COMMISSION DECISION of 23 December 2005 concerning the technical specification for interoperability relating to the subsystem ‘rolling stock — noise’ of the trans-European conventional rail system (2006/66/EC) in all the one - third - octave bands or in all the octave bands to be classified as “E”,
- shall be as the approved test track defined in annex A, point A.3 of the standard ISO EN 3095:2005 to be classified as “M”,
- exceeds at least for one third octave band, the limits as set for the approved test track defined in annex A, point A.3 of the standard ISO EN 3095:2005, to be classified as “N”,

exceeds in numerous third octave bands between the one corresponding to 0.005 m to the one corresponding to 0.160 m the spectrum defined as reference spectrum as defined in annex A, point A.3 of the standard ISO EN 3095:2005 to be classified as “B”.

Remarks on digit 12

The spectrum of the decay rate, obtained by means of the standard EN 15461:2008 is a feature which is affected by most of the components already mentioned (corresponding to digits 1, 3, 4, 5, 6, 7, 8), though mainly the track base type, the sleeper type, the rail fastener and the rail pad type. So, in general, it is recommendable to use this parameter to identify the need to introduce a new track section type, if there is a change between two different sections of track base type / sleeper type / rail fastener / rail pad type.

Simplified method	In several situations, detailed information on the different types of tracks is missing. In these situations, it is recommended to use as a minimum the classification corresponding to digit 1: B-Ballast; S-Slab track; C-Concrete bridge; E-Steel bridge; T-embedded track; O-Other.
-------------------	---

III.1.3. Number and position of the equivalent sound sources

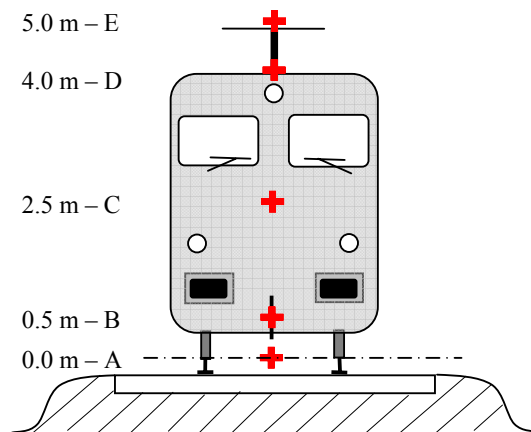

Figure III-4 – Equivalent noise sources position.

The different equivalent noise line sources are placed at different heights, and at the centre of the track. All heights are referred to the plane tangent to the two upper surfaces of the two rails.

The equivalent sources represent physical sources (index p), which are modelled in the following section III.2. These physical sources are divided depending on the generation mechanism, and are: 1) **rolling** noise (including not only rail and track base vibration and wheel vibration but also, where present, superstructure noise of the freight vehicles), 2) **traction** noise, 3) **aerodynamic** noise, 4) **impact** noise (from crossings, switches and junctions), 5) **squeal** noise, 6) **braking** noise and noise due to 7) **additional effects** such as bridges and viaducts.

1) The roughness of wheels and rail heads, through three transmission paths to the radiating surfaces (rails, wheels and superstructure), constitute the **rolling noise**. This is divided into two sound sources, allocated to $h = 0.0$ m (radiating surfaces A) to represent the track contribution including the effects of the surface of the tracks, especially slab tracks (in accordance with the propagation part), to $h = 0.5$ m (radiating surface B) to represent the wheel contribution and to $h = 2.5$ m (radiating surface C) to represent the superstructure of the vehicle to noise (in freight trains).

2) The equivalent source heights for **traction noise** vary between 0.5 m (source B), 2.5 m (source C) and 4.0 m (source D) heights, depending on the physical position of the component concerned, and can be evaluated by measurements using special techniques such as microphone array measurements. Sources such as gear transmissions and electric motors will often be at an axle height of 0.5 m (source B). Louvres and cooling outlets can be at various heights; engine exhausts for diesel powered vehicles are often at roof height of 4.0 m (source D). Other traction sources such as fans or diesel engine blocks may be at 2.5 m (source C) or 4.0 m (source D) height. If the exact source height is in between the model heights, the sound energy is distributed proportionately over the nearest adjacent source heights.

For this reason, three source heights are foreseen by the method at 0.5 m (source B), 2.5 m (source C), 4.0 m (source D), and the equivalent sound power associated with each is distributed between the three depending on the specific configuration of the sources on the unit type.

- 3) **Aerodynamic noise effects** are associated with the source at 0.5 m (representing the shrouds and the screens, source B), and the source at 4.0 m (modelling all over roof apparatus, source D, and the source exclusively representing the pantograph at 5.0 m height, source E).
- 4) **Impact noise** is associated the sources at 0.0 m and 0.5 m (source B).
- 5) **Squeal noise** is associated with the source at 0.0 m (source A) and 0.5 m (source B).
- 6) **Braking noise** is associated with the source at 0.5 m (source B).
- 7) **Bridge noise** is associated with the source at 0.0 m (source A).

N.B.: *In the following, the source heights are denoted by the index h , and each physical source by the index p , so, there can exist more source heights for the same physical source (e.g.: rolling noise at 0.0 m and 0.5 m) and different physical sources for the same source height (e.g.: rolling noise at 0.5 m and squeal noise at 0.5 m). Moreover, further on the directivity coefficient is introduced, which depends on the source type and source height, therefore, is linked both to the p and the h coefficients.*

Simplified method	In several situations, detailed information on sound power contribution of the different sources at different heights is missing. Therefore, in the simplified version of CNOSSOS-EU, it is recommended to use only the following two sources: Source B (0.5 m) for rolling noise, aerodynamic noise and traction noise, and Source D (4.0 m) for aerodynamic noise and traction noise. Impact, squeal, braking and additional effects are neglected.
-------------------	---

III.2. Sound power emission

III.2.1. General equations

Individual vehicle

The model for railway traffic noise, analogously to the road traffic noise, describes the noise sound power emission of a specific combination of vehicle type and track type, which fulfils a series of requirements described in the vehicle and track classification, in terms of sound power level per each vehicle ($L_{W,0}$). This description is consistent with the propagation calculation scheme detailed in Chapter V.

Traffic flow

The noise emission of a traffic flow on each track is to be represented to the purpose of the calculation (Chapter V) by a set of h line sources characterised by its time averaged sound power per 1-meter length. This corresponds to the sum of the sound emission due to the individual vehicles pass-by in the traffic flow, and, in the specific case of stationary vehicles, taking into account the time spent by the vehicles in the considered railway section.

The level of average sound power per track meter length, due to all vehicles pass by is defined:

- for each frequency band (*i*),
- for each track section (*j*) with the same track type (see table III -2),
- for each given source height (*h*) (sources at 0.0m *h*=1, at 0.5m *h*=2, at 2.5m *h*=3, at 4.0m *h*=4, at 5m *h*=5),

and is the energy sum of all contributions from all vehicles running on the specific *j*-th track section. These contributions are:

- from all vehicle types (*t*)
- at their different speeds (*s*)
- under the particular running conditions (constant speed, decelerating or accelerating) (*r*)
- for each physical source type (rolling, impact, squeal, braking, traction, aerodynamic, and additional effects sources such as e.g.: bridge noise) (*p*)

To calculate the average directional sound power per meter length (input to the calculation part) due to the average mix of traffic on the *j*-th track section, the following is used:

$$L_{W',eq,T,dir} = 10 \cdot \lg \left(\sum_{x=1}^X 10^{L_{w',eq,line,x}/10} \right) \quad (III-1)$$

with:

T = reference time period for which the average traffic is considered

X = total number of existing combinations of *i*, *h*, *t*, *s*, *r*, *p*, for each *j*-th track section.

t = index for vehicle types on the *j*-th track section (see Table III-1)

s = index for train speed: there will be as many indexes as the number of different average train speeds on the *j*-th track section

r = index for running conditions: 1 (for constant speed), 2 (for decelerating), 3 (for accelerating), 4 (idling)

p = index for physical source types: 1 (for rolling and impact noise), 2 (curve squeal), 3 (braking noise), 4 (traction noise), 5 (aerodynamic noise), 6 (additional effects)

L_{w',eq,line,x} = *x*-th equivalent line directional source sound power per meter of one combination of *i*, *h*, *t*, *s*, *r*, *p* on each *j*-th track section

If a steady flow of *Q* vehicles per unit time is assumed, with an average speed *v*, on average at each moment in time there will be an equivalent number of *Q/v* vehicles per unit length of the railway section. When integrating⁶, the noise emission of the vehicle flow in terms of an equivalent line source strength (time averaged directional sound power level per unit length) *L_{w',eq,line}* (expressed in dB/m (re. 10⁻¹² W)) is defined by:

⁶ The exact explanation of how this formula correctly represent the reality and can be alternatively integrated in the time or in the space is explained in the document “sound power and sound pressure definitions in CNOSSOS-EU”

$$L_{W',eq,line}(\psi, \varphi) = L_{W,0,dir}(\psi, \varphi) + 10 \times \lg\left(\frac{Q}{1000 v}\right) \quad (\text{for } r \neq 4) \quad (III-2)$$

Where:

- Q is the average number of vehicles per hour on the j -th track section for vehicle type t , average speed m and running condition r [1/s]
- v is their speed in [km/h] on the j -th track section for vehicle type t and train speed s
- $L_{W,0,dir}$ is the *directional sound power level* of the specific noise (rolling, impact, squeal, braking, traction, aerodynamic, other effects) of a single vehicle in the directions ψ, φ defined with respect to the vehicle direction of movement (see figure III-5), and is:

And, in the case of stationary source like during idling, it is assumed that the vehicle will remain for an overall time T on a location within a track section which length is L . Being T_{ref} the reference time period for the noise assessment (e.g.: 12 hours, 4 hours, 8 hours), the time averaged directional sound power level per unit length on that track section is defined by:

$$L_{W',eq,line}(\psi, \varphi) = L_{W,0,dir}(\psi, \varphi) + 10 \times \lg\left(\frac{T}{T_{ref} L}\right) \quad (\text{for } r=4) \quad (III-3)$$

$$L_{W,0,dir}(\psi, \varphi) = L_{W,0} + \Delta L_{W,dir,vert} + \Delta L_{W,dir,hor} \quad (III-4)$$

Where:

- $\Delta L_{W,dir,vert}$ is the vertical directivity correction (dimensionless) function of ψ (figure III-5)
- $\Delta L_{W,dir,hor}$ is the horizontal directivity correction (dimensionless) function of φ (figure III-5)

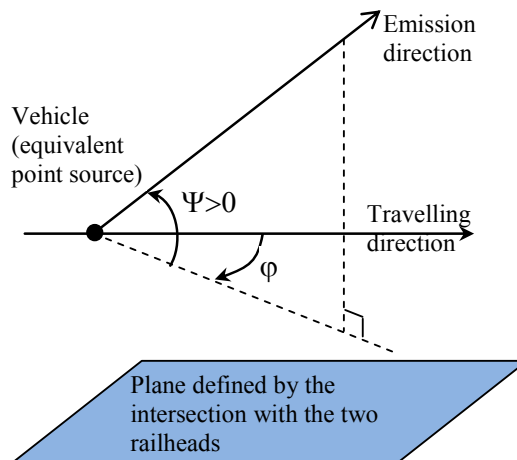

Figure III-5: Geometrical definition

For the purpose of the calculations, the source strength is then specifically expressed in terms of directional sound power per 1 m length of track $L_{W, \text{tot, dir}}$, to account for the directivity of the sources in their vertical and horizontal direction, by means of the additional corrections:

Several $L_{W,0, \text{dir}}(\psi, \varphi)$ are considered for each vehicle-track-speed-running condition combinations:

- for third octave frequency band (*i*),
- for each track section (*j*) (see table III-2),
- source height (*h*) (sources at 0.0m *h*=1, at 0.5m *h*=2, at 2.5m *h*=3, at 4.0m *h*=4, at 5m *h*=5)
- directivity (*d*) of the source.

N.B.: In the rest of this chapter, all the sound power levels and correction coefficients are intended to be expressed for each 1/3-octave band *i* (*i* = 1 to 27) in the range [25 Hz – 10 kHz] and each track section *j*. Moreover, by default, all the subscripts are implicit in all the indicators: they are omitted to improve the readability of the text.

Note: The equation (III-1) is the general equation: it shall be remarked that several combinations of indexes may not correspond to an existing equivalent sound source, e.g.: vehicle type *u*=1 may be only for constant speed (*k*=1) therefore the combination of indexes (*u, k*)=(1,2) does not correspond to an existing equivalent sound source. Also, the directivity may be not the same for all sources at a given position A, B, C, D or E.

III.2.2. Rolling noise

The vehicle contribution and the track contribution to rolling noise are separated in four essential elements: wheel roughness, rail roughness, vehicle transfer function to the wheels and to the superstructure (vessels) and track transfer function. Wheel and rail roughness represent the cause of the excitation of the vibration at the contact point between the rail and the wheel, and the transfer functions are two empirical or modelled functions that represent the entire complex phenomena of the mechanical vibration and sound generation on the surfaces of the wheel, the rail, the sleeper and the track substructure. This separation reflects the physical evidence that roughness present on a rail may excite the vibration of the rail, but will also excite the vibration of the wheel, and vice versa. Not including one of these four parameters would prevent the decoupling of the classification of tracks and trains.

III.2.2.a. Wheel and rail roughness

Rolling noise is mainly excited by rail and wheel roughness in the wavelength range from 5-500 mm.

Definition

The roughness level L_r is defined as ten times the logarithm to the base ten of the square of the mean square value r^2 (MS) of the roughness of the running surface of a rail or a wheel in the direction of motion (longitudinal level) measured in μm over a certain rail length or the entire wheel diameter), divided by the square of the reference value r_0^2 :

$$L_r = 10 \times \lg \left(\frac{r}{r_0} \right)^2 \quad dB \quad (III-5)$$

where $r_0 = 1 \mu\text{m}$

r = rms of the vertical displacement difference of the contact surface to the mean level

The roughness level L_r is typically obtained as a wavenumber λ spectrum, and it must be converted to a frequency spectrum $f = v/\lambda$, where f is the centre band frequency of a given third octave band in Hz, λ is the wavelength in m, and v is the train speed in m/s. The roughness spectrum as a function of frequency shifts along the frequency axis for different speeds.

The rail roughness level (track side roughness) for the i -th wavenumber band is defined as $L_{r,TR,i}$

In analogy, **the wheel roughness level** (vehicle side roughness) for the i -th wavenumber band is defined as $L_{r,VEH,i}$

The total and effective roughness level for wavenumber band i ($L_{R,tot,i}$) is defined as the energy sum of the roughness levels of the rail and that of the wheel plus the $A_3(\lambda)$ contact filter to consider the filtering effect of the contact patch between the rail and the wheel, and is, in dB:

$$L_{R,TOT,i} = 10 \cdot \log_{10} \left(10^{L_{r,TR,i}/10} + 10^{L_{r,VEH,i}/10} \right) + A_{3,i} \quad (III-6)$$

where $A_{3,i}$ is the contact filter expressed as a function of the i -th wavenumber band corresponding to the wavelength λ .

The contact filter depends on the rail and wheel type and the load, and for some specific common cases, it is presented in Appendix III-A.

It is practical to work with total effective roughness level as it is related directly to the real excitation. The total effective roughness $L_{R,TOT,i}$ (for wave-number band i) can be derived from rail vibration measurements or from direct roughness measurement on wheels and rails and a contact patch filter. The total effective roughness for the j -th track section and each t -th vehicle type at its corresponding v_{ts} speed is used in the method. Indirect roughness measurements can also be performed (e.g.: noise measurement under a special reference vehicle to assess the trackside roughness over long distances) to get effective rail roughness. Also, wheel roughness can be derived from databases on wheelsets based on the braking system used.

III.2.2.b. Vehicle and track transfer function

Two speed-independent transfer functions, $L_{H,tr,i}$ and $L_{H,veh,i}$, are defined for each j -th track section and each t -th vehicle type. They respectively relate the total effective roughness level with the sound power of the track and the wheels. These functions can be obtained from specific measurements but are also tabulated for some common cases in Appendix III-B.

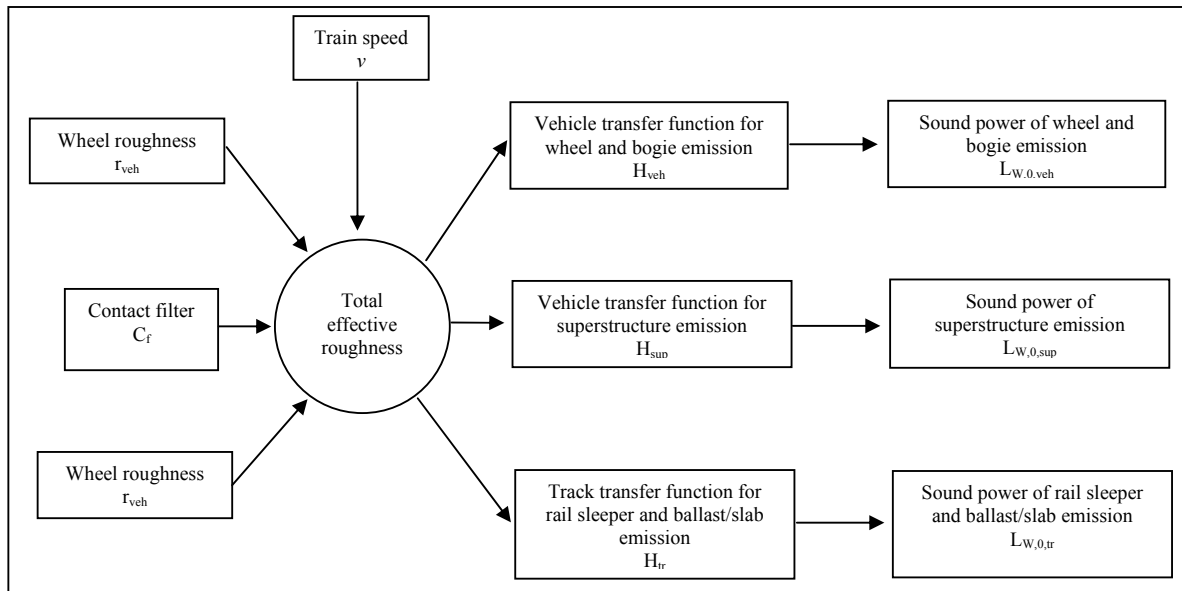

Figure III-6: Scheme of the use of the different roughness and transfer function definitions.

For rolling noise, therefore, the contributions from the track and from the vehicle are fully described by these transfer functions, and by the total effective roughness level.

For sound power per vehicle the rolling noise is calculated at rail head height (track contribution, at source *A* at 0.0 m), at axle height (vehicle contribution at source *B* at 0.5 m above rail head) and at superstructure height (vehicle contribution at source *C* at 2.5 m above rail head), and has as an input the total effective roughness level $L_{R,TOT}$ (see equation (III-6)) as a function of the vehicle speed v , the track and vehicle transfer functions $L_{H,TR}$ and $L_{H,VEH}$ and the total number of axles N_a :

for $h = 1$:

$$L_{W,0} = L_{R,TOT} + L_{H,TR} + 10 \times \lg(N_a) \quad \text{dB} \quad (III-7)$$

for $h = 2$:

$$L_{W,0} = L_{R,TOT} + L_{H,VEH} + 10 \times \lg(N_a) \quad \text{dB} \quad (III-8)$$

for $h = 3$:

$$L_{W,0} = L_{R,TOT} + L_{H,VEH,SUP} + 10 \times \lg(N_a) \quad \text{dB} \quad (III-9)$$

where N_a is the number of axles per vehicle for the t -th vehicle type

Simplified method

In the simplified version of CNOSSOS-EU, it is recommended to consider one running condition (constant speed), two transfer functions $L_{H,TR,i}$ and $L_{H,VEH,i}$ (the track transfer function is modified to consider the attribution of the sound power to the 0.5 m position instead of the 0.0 m), and, consistently with the other simplifications (i.e., on vehicle type, track type, number of source heights), to define only one total effective roughness level spectra for each of the four vehicle classes and the three track classes. A minimum speed of 70 km/h is to be used to determine the total effective roughness and therefore the sound power of the vehicles (this speed shall not affect the vehicles flow) to compensate for the potential error introduced by the simplification of rolling noise definition and impact noise from crossings and switches.

III.2.3. Impact noise (crossings, switches and junctions)

Impact noise can be caused by crossings, switches and rail joints or points. It can vary in magnitude and can dominate over rolling noise. As it is often localised, it has to be taken into account when choosing track segmentation. If present, impact noise is included in the rolling noise term by (energy) adding a supplementary fictitious impact roughness level to the total effective roughness level on each specific j -th track section where it is present. In this case a new $L_{R,TOT+IMPACT,i}$ should be used in place of the $L_{R,TOT,i}$ according to paragraph III.2.2 and it will be:

$$L_{R,TOT+IMPACT} = 10 \times \lg \left(10^{L_{R,TOT}/10} + 10^{L_{R,IMPACT}/10} \right) \text{ dB} \quad (III-10)$$

$L_{R,IMPACT,i}$ is a third octave band spectrum (as a function of frequency). To obtain this frequency spectrum, a spectrum is given as function of wavelength λ in Appendix III-C, and shall be converted to the required spectrum as function of frequency using the relation $\lambda = v_{ts}/f$, where f is the third octave band centre frequency in Hz and v_{ts} is the s -th vehicle speed of the t -th vehicle type in m/s.

Impact noise will depend on the severity and number of impacts per unit length or joint density n_l , so in case multiple impacts are given, the impact roughness level to be used in the equation (III-10) is to be calculated as follows:

$$L_{R,IMPACT} = L_{R,IMPACT-SINGLE} + 10 \times \lg \left(\frac{n_l}{0.01} \right) \text{ dB} \quad (III-11)$$

where $L_{R,IMPACT-SINGLE,i}$ is the impact roughness level as given for a single impact in Appendix III-C and n_l is the joint density.

The default impact roughness level is given for a joint density $n_l = 0.01 \text{ m}^{-1}$, which is 1 impact per 100 m track. Situations with different numbers of joints can be approximated by adjusting the joint density n_l . It should be noted that when modelling the track layout and segmentation, the rail joint density should be taken into account, i.e. it may be necessary to take a separate source segment for a stretch of track with more joints. The $L_{W,0}$ of track, wheel/bogie and superstructure contribution are incremented by means of the $L_{R,IMPACT,i}$ for +/- 50 m before and after the rail joint. In case of series of joints, the increase is extended between -50 m before the 1st joint, and +50 m after the last joint.

The applicability of these sound power spectrum should be normally verified on site.

Simplified method

In the simplified version of CNOSSOS-EU, it is recommended to consider impact noise for jointed tracks, and a default n_1 of 0,01 to be used.

III.2.4. Squeal

Curve squeal is a special source that is only relevant for curves and is therefore localised. As it can be significant, an appropriate description is required. Curve squeal is generally dependent on curvature, friction conditions, train speed and track-wheel geometry and dynamics. The emission level to be used is determined for curves with radius below or equal to 700 m and for sharper curves and branch-outs of points with radii below 300 m. The noise emission should be specific to each type of rolling stock, as certain wheel and bogie types may be significantly less prone to squeal than others. The emission level $L_{w,0}$ corresponding to the squeal is given as a function of speed and curve radius, depending on the track (curve or points) and the vehicle type. The source height is at axle height (source B at 0.5 m corresponding to index $h=2$).

Squeal noise sound power is given for different curve radii and can be approximated by the following numerical relationship which will give an equivalent -per vehicle - sound power:

$$L_{w,0} = L_{w,0}(R_0) - 20 \cdot \log_{10} \left(\frac{R_j}{R_0} \right) \text{ dB} \quad (III-12)$$

where:

R_0 is the reference radius of track curvature corresponding to 500 m,

R_j is the radius of curvature of the j -th track section,

$L_{w,0}(R_0)$ is a tabulated reference value for squeal noise for the reference radius of curvature R_0 (Appendix III-D)

The applicability of these sound power spectrum should be normally verified on site, specifically for trams.

Simplified method

In the simplified version of CNOSSOS-EU, it is recommended to approximate squeal noise to 8 dB for $R < 300$ m and 5 dB for $300 \text{ m} < R < 700 \text{ m}$.

III.2.5. Braking noise

Deceleration noise consists of braking noise at normal speeds (often broadband) and brake squeal, which usually sets in at lower speeds. The energy sum is taken for braking and brake squeal (if relevant) to give the overall deceleration noise sound power spectrum as a function of speed. The applicability of these sound power spectra should normally be verified on site.

III.2.5.a. Broadband braking noise

For braking noise with speed dependency, especially broadband braking noise, the following expression is used which will give an equivalent -per vehicle - sound power:

$$L_{W,0,bb} = L_{W,0,ref,bb}(v_0) + C_{brake} \cdot \log_{10}\left(\frac{v_{ts}}{v_0}\right) \text{ dB} \quad (III-13)$$

where:

$L_{W,0,ref,bb}(v_0)$ is a tabulated reference value for broadband braking noise for given speed v_0

C_{brake} is the speed dependency factor.

III.2.5.b. Brake squeal

For brake squeal:

$$L_{W,0,bs} = L_{W,0,ref,bs} + 10 \times \lg(d_{squeal}) \text{ dB} \quad (III-14)$$

where:

$L_{W,0,ref,bs}$ is a tabulated reference value for braking squeal

d_{squeal} is the tabulated duration correction

Overall, the braking noise is attributed at the source B at height 0.5 m and is obtained as:

$$L_{W,0} = 10 \times \lg\left(10^{L_{W,0,bb}/10} + 10^{L_{W,0,bs}/10}\right) \text{ dB} \quad (III-15)$$

The coefficients for broadband braking noise and those for brake squeal are tabulated in Appendix III-E

Simplified method	In the simplified version of CNOSSOS-EU, it is recommended that brake noise is considered to be included for speeds less than 40 km/h by adding 10 dB penalty where the speed is less than 40 km/h
-------------------	--

III.2.6. Traction noise

Traction noise is generally specific for each characteristic operating condition: constant speed (including deceleration, when it is assumed the same noise as for constant speed), acceleration and idling. The source strength is therefore here modelled for each operating condition. This results in the quantities $L_{W,0,const} = L_{W,0,dec}$ (for constant speed and decelerating respectively) $L_{W,0,acc}$ for acceleration, and $L_{W,0,idling}$ for idling. The appropriate one is to be used according to the operating condition of the train in each j -th track segment.

The $L_{W,0,idling}$ is expressed as a static noise source in the idling position, for the duration of the idling condition, and to be used modelled as a fixed point source (by means of formula (III-3)).

These quantities can either be obtained from measurement of all sources at each operating condition, or the partial sources can be characterised individually, determining their parameter dependency and relative strength. This may be done by means of measurements on a stationary vehicle, by varying shaft speeds of the traction equipment, following ISO 3095. As far as

relevant, several traction noise sources have to be characterised which might not be all directly train speed dependent:

- Noise from the power train, such as diesel engine (including inlet, exhaust and engine block), gear transmission, electrical generators, mainly dependent on engine round per minute speed (rpm), and electrical sources such as converters, which may be mostly load dependent;
- Noise from fans and cooling systems, depending on fan rpm; in some cases fans can be directly coupled to the driveline;
- Intermittent sources such as compressors, valves and others with a characteristic duration of operation and corresponding duty cycle correction for the noise emission.

As each of these sources can behave differently at each operating condition, the traction noise must be specified accordingly. The source strength is obtained from measurement under controlled conditions. In general, locomotives will tend to show more variation in loading as the number of vehicles hauled and thereby the power output can vary significantly, whereas fixed train formations such as electric motored units (EMUs), diesel motored units (DMUs) and high speed trains have a more well defined load.

There is no a priori attribution of the source sound power to the source heights, and this choice shall be made depending on the specific noise and vehicle assessed. It is here modelled to be at source B (0.5 m height), at source C (2.5 m height) and at source D (4.0 m height). In Appendix III-F, the standard proportion of traction noise to be attributed to the two sources heights is given.

Simplified method	In the simplified version of CNOSSOS-EU, it is recommended to consider only maximum load condition (the values for accelerating speed are to be used), and the sound power to be distributed between the Source B (0.5 m) and the source E (4.0 m).
-------------------	---

III.2.7. Aerodynamic noise

Aerodynamic noise is only relevant at high speeds and therefore it should first be verified whether it is actually necessary for application purposes. If the rolling noise roughness and transfer functions are known, it can be extrapolated to higher speeds and a comparison can be made with existing high speed data to check whether higher levels are produced by aerodynamic noise. If train speeds on a network are above 200 km/h but limited to 250 km/h, in some cases aerodynamic noise may not be necessary to include, depending on vehicle design.

The aerodynamic noise contribution is given as a function of speed and source height, for height at source B (0.5 m) at source D (4.0 m) and at source E (5.0 m):

$$L_{w,0} = L_{w,0}(v_0) + \alpha_2 \times \lg\left(\frac{v_{ts}}{v_0}\right) \text{ dB} \quad (III-16)$$

$$L_{W,0} = L_{W,0}(v_0) + \alpha_4 \times \lg\left(\frac{v_{ts}}{v_0}\right) \text{ dB} \quad (III-17)$$

$$L_{W,0} = L_{W,0}(v_0) + \alpha_5 \times \lg\left(\frac{v_{ts}}{v_0}\right) \text{ dB} \quad (III-18)$$

where:

v_0 is a speed at which aerodynamic noise is dominant and is fixed at 250 km/h,

α_2 is a coefficient determined from 2 or more measurement points, for sources at known source heights, for example, the first bogie (height = 0.5 m),

α_4 is a coefficient determined from 2 or more measurement points, for sources at known source heights, for example, the pantograph recess heights (height = 4m),

α_5 is a coefficient determined from 2 or more measurement points, for sources at known source heights, for example, the pantograph recess heights (height = 5m).

Coefficients for α_2 , α_4 , α_5 are given in Appendix G.

Simplified method	In the simplified version of CNOSSOS-EU, it is recommended to fully consider aerodynamic noise as presented above, for train speeds higher than 200 km/h. Sound power of the source at 5.0 m will be attributed to the 4.0m position.
-------------------	---

III.2.8. Source directivity

The horizontal directivity $\Delta L_{W,dir,hor}$ in dB is given in the horizontal plane and by default can be assumed to be a dipole for rolling, impact (rail joints etc), squeal, braking, fans and aerodynamic effects, given for each i -th frequency by:

$$\Delta L_{W,dir,hor,i} = 10 \times \lg(0.01 + 0.99 \cdot \sin^2 \varphi) \quad (III-19)$$

The vertical directivity $\Delta L_{W,dir,ver}$ in dB is given in the vertical plane for sources A (0.0 m), B (0.5 m), as a function of the centre band frequency of each i -th third octave band:

$$\Delta L_{W,dir,ver,i} = \left(\left[\frac{40}{3} \times \left[\frac{2}{3} \times \sin(2 \cdot \psi) - \sin \psi \right] \times \lg \left[\frac{f_{c,i} + 600}{200} \right] \right] \right) \quad (III-20)$$

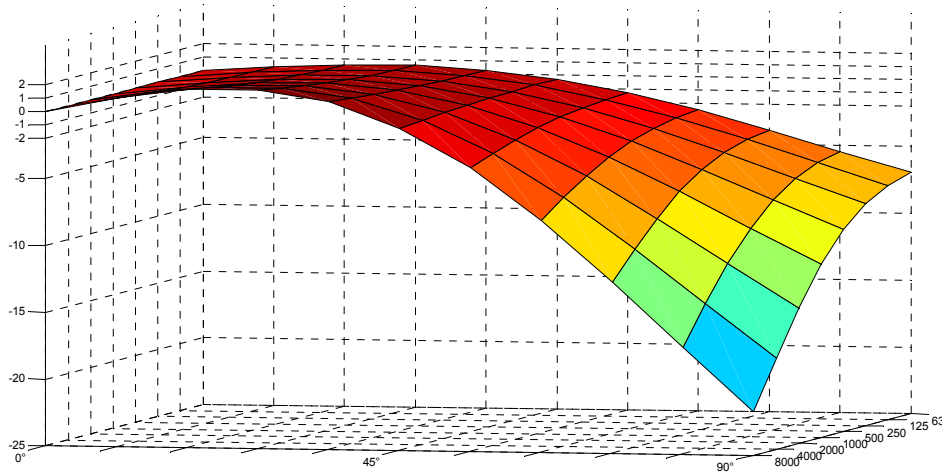

Figure III-7: Vertical directivity correction as function of angles and frequencies.

For source E (5.0m),

$$\Delta L_{W,dir,ver,i} = 10 \lg(\cos^2 \Psi) \quad \text{for } \psi < 0 \quad (III-21)$$

$$\Delta L_{W,dir,ver,i} = 0 \quad \text{elsewhere} \quad (III-22)$$

Directivity $\Delta L_{dir,ver}$ is not considered for sources C (2.5 m) and D (4.0 m), as omnidirectionality is assumed for these sources in this direction.

Simplified method	In the simplified version of CNOSSOS-EU, it is recommended to fully consider the directivity as presented above.
-------------------	--

III.3. Additional effects

III.3.1. Correction for structural radiation (bridges and viaducts)

In the case where the track section is on a bridge, it is necessary to consider the additional noise generated by the vibration of the bridge, as a result of the excitation of the presence of the train on it. Because it is not simple to model the bridge emission as an additional source, given the complex shapes of the bridges, an increase in the rolling noise is used to account for the bridge noise. The increase is modelled for the A-weighted overall level exclusively and corresponds to a fixed increase in the noise sound power. The sound power of the rolling noise only is modified so as to consider the correction and the new $L_{W,0,rolling-and-bridge}$ is to be used instead of : $L_{W,0,rollingonly}$

$$L_{W,0,rolling-and-bridge} = L_{W,0,rollingonly} + C_{bridge} \text{ dB} \quad (III-23)$$

where C_{bridge} is a constant that can be obtained depending on the bridge type from the table in Appendix III-H, and $L_{W,0,rollingonly}$ is the rolling noise sound power on the given bridge depending on the vehicle and track properties only.

Simplified method	In the simplified version of CNOSSOS-EU, it is recommended to fully consider the structural radiation as presented above.
-------------------	---

III.3.2. Correction for other railway related noise sources

Various sources like depots, loading/unloading areas, stations, bells, station loudspeakers can be present and are associated with the railway noise. These sources are to be treated as industrial noise sources (fixed noise sources) and therefore for a correct modelling the chapter IV shall be addressed.

References

- [14] prEN 15610, *Railway applications - Noise emission - Rail roughness measurement related to noise generation*, CEN, Jan 2009.
- [15] U. Moehler, U. J. Kurze, M. Liepert, H. Onnich, *The new German prediction model for railway noise "Schall 03 2006": an alternative method for the Harmonised calculation method proposed in the EU Directive on environmental noise*, Acta Acustica united with Acustica, Vol. 94, p 548-552, 2008.
- [16] M. Dittrich, *The IMAGINE source model for railway noise prediction*, Acta Acustica united with Acustica, Vol. 93, p 185-200, 2007.
- [17] R. R. K. Jones, M. Dittrich, P. van der Stap, X. Zhang, J. R. Block, *Rail noise database and manual for implementation*, EU-FP6 project "IMAGINE" report (IMA6TR-061015-AEATUK10), AEATUK, 2007
- [18] U. Moehler, M. Liepert, U. Kurze, H. Onnich, *The new German prediction model for railway noise „Schall 03 2006“ – some proposals for the harmonised calculation method in the EU directive on environmental noise*, proceedings of Euronoise 2006, Tampere, Finland, 2006.
- [19] C. Talotte, P. van der Stap, M. Ringheim, M. Dittrich, X. Zhang, D. Stiebel, *Railway source models for integration in the new European noise prediction method proposed in Harmonoise*, Journal of Sound and Vibration 293, p 975–985, 2006.
- [20] *SCHALL 03 2006, Richtlinie zur Berechnung der Schallimmissionen von Eisenbahnen und Straßenbahnen Entwurf*, Stand: 21.12.2006, Germany, Dec 2006.
- [21] *Vorläufige Berechnungsmethode für den Umgebungslärm an Schienenwegen VBUSch 10*, Germany, May 2006.
- [22] M. G. Dittrich, *IMAGINE railway noise source model, default source data and measurement protocol*, EU-FP6 project "IMAGINE" report (IMA6TR-050912-TNO01), TNO, 2005.
- [23] R. R. K. Jones, *Measured railway noise source data in the public domain or via the Imagine project*, EU-FP6 project "IMAGINE" report (IMA6TR-050110-AEATUK01), AEATUK, 2005.

- [24] UNI EN ISO 3095, *Applicazioni ferroviarie, Acustica, Misurazione del rumore emesso dai veicoli su rotaia*, October 2005
- [25] A. Van Beek, M. Beuving, M. Dittrich, M. Beier, X. Zhang, H. Jonasson, F. Letourneaux, C. Talotte, M. Ringheim, *Work package 1.2, rail sources, state of the art*, EU-FP5 project “HARMONOISE” report (HAR12TR-020118-SNCF10), SNCF, 2005
- [26] A.E.J. Hardy, R.R.K. Jones, *Rail and wheel roughness - implications for noise mapping based on the Calculation of Railway Noise procedure*, AEA Technology Rail report, March 2004.
- [27] A.E.J. Hardy, R.R.K. Jones, C.E. Wright, *Additional railway noise source terms for "Calculation of Railway Noise 1995"*, DEFRA Report, May 2004.
- [28] C. Talotte, *WP1.2 Rail sources, railway source model and user manual of the database*, EU-FP5 project “HARMONOISE” report (HAR12TR-040112-SNCF10 (D13p1)), SNCF, 2004.
- [29] P. van der Stap, X. Zhang, M. Dittrich, *IMAGINE – userinterface database*, EU-FP6 project “IMAGINE” report (MA6MO-041014-AEATNL02), AEA, 2004.
- [30] E. Verheijen, D. Stiebel, M. Dittrich, A. van Beek, P. van der Stap, *Definition of other sources and influence of source measures*, EU-FP5 project “HARMONOISE” report (HAR12TR-030625-AEA11 (D12p3)), AEA, 2004.
- [31] M. Beuving, M. Paviotti, *Definition of track influence: track composition and rolling noise*, EU-FP5 project “HARMONOISE” report (HAR12TR-030403-AEA10), AEA, 2003.
- [32] A. van Beek, E. Verheijen, , *Definition of track influence: roughness in rolling noise*, EU-FP5 project “HARMONOISE” report (HAR12TR-020813-AEA10), AEA, 2003.

Appendix III-A (to be added at a later stage)

The contact filter depends on the rail and wheel type and the load, and for some specific common cases, it is presented here.

Appendix III-B (to be added at a later stage)

Two speed-independent transfer functions, $L_{H,tr,i}$ and $L_{H,veh,i}$, are defined for each j -th track section and each t -th vehicle type. They respectively relate the total effective roughness level with the sound power of the track and the wheels. These functions can be obtained from specific measurements but are also tabulated for some common cases here.

Appendix III-C (to be added at a later stage)

$L_{R,IMPACT,i}$ is a third octave band spectrum (as a function of frequency). A default spectrum is given as function of wavelength λ here.

Appendix III-D (to be added at a later stage)

Parameters for default calculation of squeal noise are presented here.

Appendix III-E (to be added at a later stage)

Parameters for default calculation of braking noise are presented here.

$L_{W,0,ref,bb}(v_0)$, the reference value for broadband braking noise for given speed v_0 , is tabulated here.

C_{brake} the speed dependency factor, is tabulated here.

$L_{W,0,ref,bs}$ the reference value for braking squeal, is tabulated here.

d_{squeal} the duration correction for braking squeal, is tabulated here.

Appendix III-F *(to be added at a later stage)*

The standard proportion of traction noise to be attributed to the two sources heights is given here.

Appendix III-G *(to be added at a later stage)*

Parameters for default calculation of aerodynamic noise are presented here.

The default suggested values are: $\alpha_2 = \alpha_4 = \alpha_5 = 50$

Appendix III-H *(to be added at a later stage)*

C_{bridge} is a constant that can be obtained depending on the bridge type from the table presented here.

CHAPTER IV. INDUSTRIAL NOISE SOURCE EMISSION

IV.1. Source description

IV.1.1. Classification of source types (point, line, area)

The industrial sources are of very variable dimensions, they can be large industrial plants as well as small concentrated sources like small tools or operating machines used in factory. Therefore, it is necessary to use an appropriate modelling technique for the specific source under assessment. Depending on the dimension and the way several single sources extend over an area, though belonging to the same industrial site, these are better modelled as point sources, line source or area source. In practice, the calculations of the noise effect is always based on point sources, but several point sources can be used to represent a real complex source which mainly extends over a line or an area.

IV.1.2. Number and position of equivalent sound sources

The sound sources are modelled as one or more equivalent point sources so that the total sound power of the source corresponds to the sum of the single sound powers attributed to the different point sound sources.

The general rule to be applied in defining the number of equivalent point sources to be used is that:

- Line or surface sources whose largest dimension is less than $1/2$ of the distance between the source and the receiver can be modelled as single point sources.
- Sources whose largest dimension is more than $1/2$ of the distance between the source and the receiver shall be modelled as a series of point sources in a line or as a series of point sources over an area, such that for each of these sources the conditions of $1/2$ is fulfilled. The distribution over an area can include vertical distribution of point sources.
- Sources whose largest dimensions in height are over 2 meter or are near the ground, special care should be administered to the height of the source. Doubling the number of sources, redistributing them only in the z-component, may not lead to a relevant other result for this source.
- In the case of any source, doubling the number of sources over the source area (in all dimensions) may not lead to a relevant other result.

The position of the equivalent sound sources cannot be fixed, given the large number of configurations that an industrial site can have. Best practice shall normally apply.

IV.2. Sound power emission

IV.2.1. General

The following information constitutes the complete set of input data for sound propagation calculations with the methods to be used for noise mapping:

- Emitted sound power level spectrum in 1/3 octave bands
- Working hours (day, evening, night, on a yearly averaged basis)
- Location (coordinates x, y) and elevation (z) of the noise source
- Type of source (point-, line-, area- source)
- Dimensions and orientation
- Operating conditions of the source
- Directivity of the source

It shall be noted that not all of the information above is equally important as the impact on the noise mapping results is different. This becomes important if only limited or no data for individual quantities is available. For example, while knowing the sound power level of the source and its operating condition is crucial, lacking knowledge of the directivity may still lead to an acceptable noise map as a result of the co-existence of many sources.

The point, line and area source sound power are required to be defined as:

- For a point source, sound power L_W and directivity as a function of the three orthogonal coordinates (x, y, z) ;
- Two types of line sources can be defined:
 - line sources representing conveyor belts, pipe lines, etc. , sound power per meter length $L_{W/m}$ and directivity as a function of the two orthogonal coordinates to the axis of the equivalent line source;
 - line sources representing moving vehicles, sound power L_w and directivity as a function of the two orthogonal coordinates to the axis of the equivalent line source and the speed and number of vehicles travelling along this line during day, evening and night;
- For an area source, sound power per squared meter L_{W/m^2} , and no directivity (may be horizontal or vertical).

The working hours are an essential input for the calculation of noise levels. The working hours should be given for the day, evening and night period and, if the propagation is using different meteorological classes defined during each of the day, night and evening period, then a finer distribution of the working hours should be given in sub-periods matching the distribution of meteorological classes. This information shall be based on a yearly average.

The correction for the working hours, to be added to the source sound power to define the corrected sound power to be used for calculations over each time period, C_W in dB, is calculated as follows:

$$C_W = 10 \times \lg\left(\frac{t}{T_0}\right) \quad (IV-1)$$

where:

t is the active source time per period based on a yearly averaged situation, in hours;

T_0 is the reference period of time in hours (e.g.: day: 12 hours, evening: 4 hours, night: 8 hours].

For the more dominant sources, the yearly average working hours correction should be estimated at least within 0.5 dB tolerance in order to achieve an acceptable accuracy (this is equivalent to an uncertainty of less than 10% in the definition of the active period of the source).

IV.2.2. Source directivity

The source directivity is strongly related to the position of the equivalent sound source next to nearby surfaces. Because the propagation method considers the reflection of the nearby surface as well its sound absorption, it is necessary to consider carefully the location of the nearby surfaces. In general, it shall always be distinguished between the two cases:

- a source sound power and directivity is determined and given relative to a certain real source when this is in free field (excluding also the terrain effect);
- a source sound power and directivity is determined and given relative to a certain real source when this is placed in a specific location and therefore the source sound power and directivity is in fact an “equivalent” one, since it includes the modelling of the effect of the nearby surfaces.

The method can handle both cases, under the following conditions:

- in case the source sound power and directivity is given following the first rule, nearby surfaces should at least be 0.01 m from the equivalent point source;
- in case the source sound power and directivity is given following the second rule, nearby surfaces already included in the definition of the source shall not be included in the propagation calculation for this source.

The directivity shall be expressed as a factor $\Delta L_{W,dir,xyz}(x, y, z)$ to be added to the sound power to obtain the right equivalent sound power of a reference sound source seen by the sound propagation in the direction given. The factor can be given as a function of the direction vector defined by (x,y,z) with $\sqrt{x^2 + y^2 + z^2} = 1$.

IV.2.3. Measurements

In traffic noise one can assume that the variety of different cars over a whole year can be taken as a standard averaged car with a certain speed. This is not the case for industry, the same sources tends to be there for a very long time, no averaging takes place. Therefore each relevant source should be measured to get accurate sources and noise maps.

There exists a considerable number of standards and guidelines on measurement methods for industrial noise sources. These standards are meant to be the best practices to use for the

determination of sound power levels and directivity for different source types, from extended sources like industrial sites as a whole, to small appliances and machinery.

The following is a classification of such set of standards to be used.

- Standards that describe general methods for classes of noise sources, special methods for specific single noise sources or methods for whole plants or industries
- Standards that are originally intended to provide data for the assessment of
 - the source sound power level
 - working place noise
 - a comparison of the noise emissions of different sources of a kind
 - noise emissions under specific operating conditions
- Standards that apply to measurements in the field or in special test rooms
- Standards of different grades of accuracy
- Standards that require special measuring equipment

It is logical to rely on these standards also for measurements the objective of which is the determination of source sound power level and directivity to be used with this method. A list of such standards is given in **Appendix IV-A** (*to be integrated at a later stage*).

Unfortunately, the methods described in the standards are often not specifically intended to provide input data for noise mapping purposes, so that there may be certain shortcomings in using a specific standard for that purpose even if, in principle, it is applicable to the source(s) in question. On the other hand, in some cases, the described methods can be improved by simple means to yield the desired information even if they were not originally aimed at providing that information.

Accordingly, the end user, searching for an appropriate measurement method for his/her particular sound source to acquire input data for noise mapping, has to choose from these different standards.

IV.2.4. Use of pre-defined database

When it is not possible to measure the individual sources, a database can be used for determining the source sound power and directivity as well as typical working hours, to be used for each source. A default database is given in **Appendix IV-B** (*to be integrated at a later stage*).

References

- [1] G. Licitra, P. Gallo, *Noise impact modelling of IPPC industrial activities for Pisa strategic noise mapping*, acts of ICSV16, Krakow, Poland, 2009.
- [2] J. Witte, *Description of the source database, WP7: industrial noise*, EU-FP6 project “IMAGINE” report (IMA07TR-050418-DGMR02), DGMR, 2007.
- [3] R. Witte, *Industrial noise in IMAGINE*, acts of INTERNOISE 2007, Istanbul, 2007.
- [4] C. Hantschk, *Measurement methods, WP7: Industrial Noise*, EU-FP6 project “IMAGINE” report (IMA07TR-050418-MBBM03), Müller-BBM GmbH, 2005.
- [5] *Work package: WP4 Description of database (Version VI)*, EU-FP5 project “HARMONOISE” report (HAR04MO040507dBA01), deBAKOM, 2004.

CHAPTER V. SOUND PROPAGATION

The sound propagation model described in this chapter is based on the formulations developed within the “HARMONOISE” EU FP5 project. This model was initially described in [1]. Interactions with the NORD2000 model [2] are also clear. Later, in the frame of the EU FP6 project “IMAGINE”, the physical background of the HARMONOISE model was detailed in [3]. Recently, an improved description of the model was proposed in [4]. The point-to-point model of CNOSSOS-EU is widely based on these reference papers, in particular this latter description.

V.1. Set up of the model

V.1.1. Geometrical considerations

This section presents only the basic concepts of the geometrical model. More details will be provided in the Guidance for the competent use of CNOSSOS-EU.

V.1.1.a. Source segmentation

Real sources are described by a set of point source or, in the case of a railway traffic or road traffic, by incoherent line sources. A line source is divided into line segments, which are represented by point sources located at their centre.

Different techniques exist for the source segmentation. These will be discussed in the Guidance for the competent use of CNOSSOS-EU.

Simplified method	In the simplified version of CNOSSOS-EU, computational time can be reduced by reducing the number of point sources: this can be achieved by using longer segments, and, in the case of road traffic, a reduced number of lanes.
-------------------	---

V.1.1.b. Propagation paths

As mentioned in section I.3.1, CNOSSOS-EU operates on a geometrical model consisting of a set of connected surfaces [9]. A propagation path is a vertical plane through the receiver and a point source. The calculation of the contribution of a source to the sound level at the receiver is a two step process:

- First, a two dimension search is operated in the horizontal plane to construct propagation paths. This process is referred to as the “path finder” part of the method. The outcome of this process is a vertical plane connecting the receiver and the source.
- Next, a geometrical analysis is performed in the vertical plane of the propagation path in order to estimate the effects of ground reflections, diffraction over obstacles and meteorological refraction.

V.1.1.c. Reflections by building façades and other vertical obstacles

Contributions from reflections are taken into account by the introduction of image sources or image receivers. Subsequent reflections are to be taken into account up to a maximum reflection depth of 3 reflections.

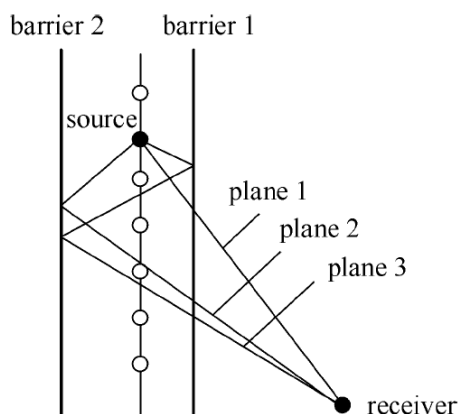

Figure V-1: Top view of (vertical) propagation planes 1, 2, and 3 for a point source in a situation with barriers on either side of the road. Each barrier reflection corresponds to one (or more) kink(s) in a propagation plane (from [5]).

Simplified method	In the simplified version of CNOSSOS-EU, it is recommended to reduce the maximum number of reflections (for instance to one).
-------------------	---

V.1.1.d. Input to the point-to-point calculation

The ground profile in the vertical cross-section from the source to the receiver is described by a set of N straight segments with end points P_i with $i = 0, 1, 2, \dots, N$ (figure V-2). The geometrical model does not distinguish between natural terrain and other obstacles such as barriers, buildings, embankments, cuttings, etc. The coordinates of the point P_i in the xz plane are (x_i, z_i) with $x_{i+1} > x_i$.

The real source S_r is positioned at $(x_0, z_0 + H_S)$ and the real receiver R_r at $(x_N, z_N + H_R)$ where H_S and H_R are the local heights of respectively the source and receiver. Note that generic source/receiver positions are used inside the calculation of sound propagation, representing either the real source/receiver, or secondary sources/receivers at diffraction edges. They are noted S or R without any subscript.

For the introduction of atmospheric refraction, a curvature of the ground profile is performed, as described in section V.5.2. This analogy consists in applying a coordinate change to the points P_i defining the ground profile. However, the relative source and receiver heights above the transformed profile, respectively H_S and H_R , remain unchanged.

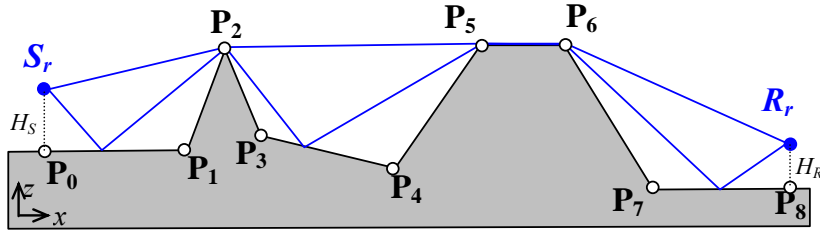

Figure V-2: Example of ground profile between source and receiver points

Each segment $[P_{i-1}, P_i]$ is assigned with a specific impedance value Z_i . Impedance values can be calculated using available models, or for simplicity, they can be predefined in impedance classes. However, in the specific case of a road paved with a porous surface layer, impedance corresponding to a purely reflecting surface should be applied (see chapter II).

Simplified method	Simplifications on the description of ground profiles and optimization of the number of ground segments will be proposed in the Guidances for competent use of CNOSSOS-EU.
-------------------	--

V.1.2. Sound propagation model

V.1.2.a. Point-to-point attenuation: main formulation

The equivalent sound pressure level $L_{eq,T,i}$, caused by a source (represented by a point source with source power output L_w) is calculated by:

$$L_{eq,T,i} = L_{W,eq,T,i} + \Delta L_{geo} + \Delta L_{atm,i} + \Delta L_{excess,i} + \Delta L_{refl+diff,i} + \Delta L_{special,i} \quad (V-1)$$

where

- $L_{eq,T,i}$ is the equivalent sound pressure level over the period of observation T
- $L_{W,eq,T,i}$ is the equivalent sound power of the source over the same period T (note that L_w should read L_w' in case of a line source segment). It is the output of the source model as defined in Chapter II, III and IV.
- ΔL_{geo} is the geometrical spreading
- $\Delta L_{atm,i}$ is the atmospheric absorption
- $\Delta L_{excess,i}$ is the excess attenuation, i.e. the level difference due to ground, diffraction and meteorological effects
- $\Delta L_{refl+diff,i}$ is a correction term for reflection and diffraction by vertical obstacles.

$\Delta L_{special,i}$ is a correction term for special cases that are to be considered extensions to the basic CNOSSOS-EU method described in this chapter, e.g. for handling complex 3D situations that do not fit the framework of the simplified geometrical construction of propagation paths. Some examples may be given in the Guidance for the competent use of CNOSSOS-EU.

The equivalent sound pressure level $L_{eq,T,i}$ at the receiver position is calculated by incoherent summation over all (N_p) propagation paths.

$$L_{eq,T,i} = 10 \times \lg \sum_{n=1}^{N_p} 10^{L_{eq,T,i,n}/10} \quad (V-2)$$

V.1.2.b. Geometrical attenuation

The geometrical divergence accounts for spherical spreading of the emitted acoustical energy from a point source in the free field. It does not depend on frequency and is given by:

- **For a point source**

$$\Delta L_{geo} = 10 \times \lg \left[\frac{1}{4\pi R^2} \right] \quad (V-3a)$$

where R is the distance from the source to the receiver in m.

- **For a line segment source** (short enough so that variations of the source directivity and the excess attenuation can be ignored as the source moves from one end of the segment to the other) :

$$\Delta L_{geo} = 10 \times \lg \left[\frac{\Delta\theta}{4\pi R_{min}} \right] \quad (V-3b)$$

where $\Delta\theta$ is the angle of view and R_{min} the shortest distance from the receiver to the (infinite) line supporting the line source segment.

The parameters R , R_{min} and $\Delta\theta$ shall be determined using 3D coordinates. An operational calculation scheme as well as valid solutions for the case $R_{min} \rightarrow 0$ will be given in the Guidelines for a Competent Use.

Note that if the source line is decomposed in a fixed distribution of point sources, equation (V-3a) applies and the equivalent sound power of each point source is given by:

$$L_{W,s} = L_{W',s} + 10 \times \lg l_s \quad (V-3c)$$

Comparison of equations (V-3a) and (V-3b) shows that an accurate estimate of l_s is given by:

$$\sin \psi = \frac{R_{min}}{R} \Rightarrow l_s = \frac{R \cdot \Delta\theta}{\sin \psi} \quad (V-3d)$$

Where ψ is the angle between the source line and the ray path. Therefore, equation (V-3c) and (V-3d) can also be used in combination with an angular scanning method. Equation (V-3d) is valid under the condition that $\sin \psi > 0$, i.e. special care should be taken in case the receiver is (almost) in line with the source line segment.

In case the directivity pattern cannot be neglected over the length of the segment, the combined effect of geometrical divergence and directivity can be calculated as:

$$\Delta L_{geo+dir} = 10 \times \lg \int_{s=s_1}^{s=s_2} \frac{D(\theta)}{4\pi d^2} ds \quad (V-4)$$

where θ and d shall be considered functions of the curvilinear coordinate s along the source segment. For simple directivity functions $D(\theta)$, this integral can be worked out analytically; for complex directivity, one should rely on numerical integration techniques.

Note: If the directivity of the source depends on the frequency, then $\Delta L_{geo+dir}$ must also be considered a function of frequency.

V.1.2.c. Atmospheric absorption

The attenuation due to atmospheric absorption $\Delta L_{atm,i}$ depends on frequency and should be calculated at centre frequency f of each 1/3 octave band. It is given by:

$$\Delta L_{atm,i} = -\alpha_{atm,i} \times R \times \left(1.0053255 - 0.00122622 \times \alpha_{atm,i} \times R\right)^{1.6} \quad (V-5)$$

where $\alpha_{atm,i}$ is the atmospheric attenuation coefficient in dB/m, given in [6] for pure tones.

V.2. Excess attenuation

V.2.1. Diffraction, ground reflection and scattering

The excess attenuation ΔL_{excess} is the combination of two components:

$$\Delta L_{excess} = 10 \times \lg \left(10^{\Delta L/10} + 10^{\Delta L_{scat}/10}\right) \quad (V-6)$$

where

ΔL is the part of the sound wave that reaches the receiver by diffraction and reflection on the ground profile. It is described in the following of this section and in sections V-3 and V-4.

ΔL_{scat} is the part of the sound wave that reaches the receiver after scattering by atmospheric turbulence. It is described in section V-6.

Note that the excess attenuation is frequency dependent and should be calculated at central frequency of each 1/3 octave band.

V.2.2. Recursive process

For the calculation of ΔL , the ground profile is divided into a number of ground sections between diffraction edges. As an example, in Figure V-2, the diffracting edges are P_2 , P_5 and P_6 , and the ground sections are P_0 - P_2 , P_2 - P_5 , P_5 - P_6 and P_6 - P_8 .

Then the excess attenuation results from the combination of the diffraction attenuations ΔL_D on the diffraction edges and the ground attenuations ΔL_G on the ground sections.

The calculation scheme is based on a recursive process in three steps. The detailed algorithm is taken from [4]. Basically:

Step 1: From the ground vertices $P_i (x_i, z_i)$ the set of points $P_{i^*} (x_i, z_i + H_i)$ is derived, with $H_0 = H_S$, $H_N = H_R$, and $H_i = 0$ for $i = 1, \dots, N-1$. Thus $P_{i^*} = \{S_r, P_1, P_2, \dots, P_{N-1}, R_r\}$ for $i = 0, \dots, N$.

Step 2: Indices i and j are initialized to $i = 0$ and $j = N$.

Step 3: The excess attenuation $\Delta L = \Delta L(P_i, P_j)$ is calculated.

First the set of points P_k with $i < k < j$ above the line from source point P_{i^*} to receiver point P_{j^*} is determined.

- If the set of points P_k is empty, the result ΔL of step 3 is equal to the ground attenuation $\Delta L_G(P_i, P_j)$. In this case, there are no diffraction edges above the line from the source to the receiver, and $\Delta L = \Delta L_G$, where ΔL_G is calculated using the transition model described in V.4.3.
- If the set of points P_k is not empty, then the following two sub-steps are performed.
 - i) From the set of points P_k , the point P_k with the largest path length difference is selected. The path length difference is defined by:

$$\delta(P_{i^*}, P_k, P_{j^*}) = d(P_{i^*}, P_k) + d(P_k, P_{j^*}) - d(P_{i^*}, P_{j^*}) \quad (V-7)$$

where $d(P, Q)$ is the distance between points P and Q .

- ii) The result ΔL of step 3 is given by:

$$\Delta L = \Delta L_D(P_{i^*}, P_k, P_{j^*}) + \Delta L(P_i, P_k) + \Delta L(P_k, P_j) \quad (V-8)$$

where the term ΔL represents a diffraction attenuation for the sound path $P_{i^*} - P_k - P_{j^*}$ and the last two terms are determined by repeated application of step 3.

The first time step 3 is performed, P_{i^*} and P_{j^*} correspond to the real source S_r and the real receiver R_r , respectively. The next times, however, P_{i^*} and/or P_{j^*} correspond to a secondary source S at a diffraction edge and/or a secondary receiver R at a diffraction edge, respectively.

The calculation of the diffraction attenuation ΔL_D is described in section V-3. The calculation of the ground attenuation ΔL_G is described in section V-4.

V.3. Diffraction attenuation

The diffraction attenuation ΔL_D is given by the approximate solution of Deygout [7]:

$$\Delta L_D = 0 \quad \text{for } N_f < -0.25 \quad (V-9a)$$

$$\Delta L_D = -6 + 12\sqrt{-N_f} \quad \text{for } -0.25 \leq N_f < 0 \quad (V-9b)$$

$$\Delta L_D = -6 - 12\sqrt{N_f} \quad \text{for } 0 \leq N_f < 0.25 \quad (V-9c)$$

$$\Delta L_D = -8 - 8\sqrt{N_f} \quad \text{for } 0.25 \leq N_f < 1 \quad (V-9d)$$

$$\Delta L_D = -16 - 10 \lg N_f \quad \text{for } N_f \geq 1 \quad (V-9e)$$

where N_f is the Fresnel number given by:

$$N_f = \frac{2\delta}{\lambda} \quad (V-10)$$

where λ is the acoustic wavelength and δ the (signed) geometrical path length difference between the diffracted ray path $[S-P-R]$ and the direct path $[S-R]$, as depicted in figure V-3.

In figure V-3, the angles θ_S , $\theta_{S'}$, θ_R and $\theta_{R'}$ are evaluated with respect to the vertical line at the diffracting point P. On the source S side, the angles θ_S and $\theta_{S'}$ are positive to the counter clockwise, whereas on the receiver R side, the angles θ_R and $\theta_{R'}$ are positive to the clockwise. Diffraction angles θ_S and θ_R are in the range $[0, \pi]$. Note that the image source S' and image receiver R' positions are used for the consideration of ground attenuation (section V-4). Related diffraction angles $\theta_{S'}$ and $\theta_{R'}$ are in the range $[0, 2\pi]$, **i.e. images may be on the opposite side of their original with respect to the diffracting edge.**

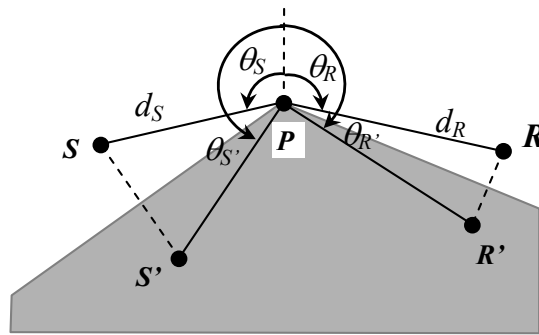

Figure V-3: Diffraction geometry with source S , receiver R and diffracting point P ; S' is the image source and R' the image receiver; d_S is the distance (S,P) and d_R the distance (P,R) ; θ_S and $\theta_{S'}$ are positive to the left (counter clockwise), θ_R and $\theta_{R'}$ are positive to the right (clockwise).

For the expression of δ , two regions are considered with respect to the total angle of deflection $\theta = \theta_S + \theta_R$ (when considering all possible combinations, θ is in the range $[0, 4\pi]$): $\theta \leq \pi$ and $\theta > \pi$.

For $\theta \leq \pi$, the usual definition of the path length difference δ applies:

$$\delta = -(d_S + d_R - d_d) \quad (V-11)$$

with the direct path length

$$d_d = \sqrt{d_S^2 + d_R^2 - 2d_S d_R \cos \theta} \quad (V-12)$$

Note that $\delta \leq 0$ in this case, and that the diffracting edge is below the line of sight connecting the source and the receiver.

For $\theta > \pi$, i.e. in the shadow zone behind the diffracting obstacle, an analytical extrapolation of the geometrical definition of the path length difference is made:

$$\delta = d_d \left(\frac{1}{2} \varepsilon^2 + \frac{1}{3} \varepsilon^4 \right) \quad (V-13)$$

with
$$d_d = (d_S + d_R) \quad (V-14)$$

and
$$\varepsilon = \frac{\sqrt{d_S d_R}}{d_S + d_R} (\theta - \pi) \quad (V-15)$$

For the introduction of ground attenuation, the amplitude of the diffracted sound pressure p_D is used (section V-4). It is defined in its normalised form, by:

$$p_D = \frac{e^{ik_0 d_d}}{d_d} 10^{\Delta L_D / 20} \quad (V-16)$$

with d_d defined as above for $\theta \leq \pi$ and $\theta > \pi$.

V.4. Ground attenuation

V.4.1. Concave ground model

Ground attenuation is calculated in a d-h coordinate system attached to each ground segment (see figure V-4). The d-axis is aligned with the extension of the segment to an infinite line, the h-axis is perpendicular to the d-axis and pointing upwards. Note that in case of a complex terrain profile, each segment will give way to a different coordinate system. Let h_S and h_R be the heights of the source and receiver as measured in these local coordinates.

The method distinguishes three types of ground segments:

- concave ground segments for which the source and receiver are both above its extension to infinite length (i.e. $h_S \geq 0$ and $h_R \geq 0$);
- convex ground segments for which the source or the receiver (or either one of them replaced by the nearest diffracting edge on the profile) is below the extended segment (i.e. $h_S < 0$ or $h_R < 0$);
- hull segments where both the source and the receiver and all of the (eventual) diffraction points are below its extension (basically $h_S = h_R = 0$).

In this section, situation with only concave ground segments and hull segments are treated. Convex ground segments are addressed in section V.4.3.

In the formulas below, the concave ground attenuation ΔL_{Gc} is calculated for the propagation from a (secondary) source at position $P_{i^*}(x_i, z_i + H_i)$ to a (secondary) receiver at position $P_{j^*}(x_j, z_j + H_j)$ over ground profile $P_k(x_k, z_k)$ with $k = i, \dots, j$.

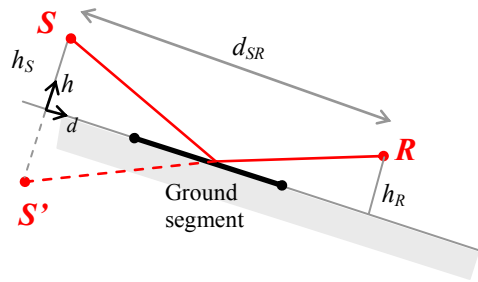

Fig. V-4: Local geometrical definitions

V.4.1.a. Ground attenuation of concave segments

The ground attenuation for concave segments ΔL_{Gc} is defined as a weighted average of two different ground attenuations:

$$\Delta L_{Gc} = F_G \Delta L_{G,flat} + (1 - F_G) \Delta L_{G,valley} \quad (V-17)$$

where

- $\Delta L_{G,flat}$ is the ground attenuation for relatively flat ground
- $\Delta L_{G,valley}$ is the ground attenuation for valley-shaped terrain

The parameter F_G is given by:

$$F_G = 1 - e^{-1/x_G^2} \quad (V-18)$$

with

$$x_G = N_W / \sqrt{1 + (f/f_c)^2} \quad (V-19)$$

$$N_w = \sum_{k=i}^{j-1} w_k \quad (V-20)$$

w_k are modified Fresnel weights of the ground segments and f_c is a transition frequency. Both are defined in section V.4.2.

The ground attenuation $\Delta L_{G,flat}$ is given by:

$$\Delta L_{G,flat} = \sum_{k=i}^{j-1} w_k \Delta L_{G,flat,k} \quad (V-21)$$

with
$$\Delta L_{G,flat,k} = 10 \times \lg \left(\left| 1 + C_k D_k Q_k \right|^2 + \left(1 - C_k^2 \right) \left| D_k Q_k \right|^2 \right) \quad (V-22)$$

The ground attenuation $\Delta L_{G,valley}$ is given by:

$$\Delta L_{G,valley} = -10 \times \lg \left(\left| 1 + \sum_{k=i}^{j-1} w_k C_k D_k Q_k \right|^2 + \sum_{k=i}^{j-1} w_k \left(1 - C_k^2 \right) \left| D_k Q_k \right|^2 \right) \quad (V-23)$$

In this last two formulas,

- Q_k is a spherical-wave reflection coefficient (see section V.4.1.b),
- D_k is a geometrical weighting factor (see section V.4.1.c)
- C_k is a coherence factor (see section V.4.1.d),
- w_k is a modified Fresnel weight (see section V.4.2.b).

The summations in equations (V-20) (V-21) and (V-23) are over the ground segments $k = i, \dots, j-1$ between the source and the receiver.

V.4.1.b. Spherical-wave reflection coefficient

The spherical-wave reflection coefficient Q_k is calculated for the ground segment k , by:

$$Q = \mathcal{R}_p + (1 - \mathcal{R}_p) F_Q^{n_g} \quad (V-24)$$

where \mathcal{R}_p is the plane wave reflection coefficient:

$$\mathcal{R}_p(\theta) = \frac{Z \cos(\theta) - 1}{Z \cos(\theta) + 1} \quad (V-25)$$

where θ is the angle of reflection with respect to the normal of the surface, and Z is the normalised ground impedance.

F_Q is the boundary loss factor given by Chien and Soroka [8].

The coefficient n_G was introduced in order to improve the solution of Chien and Soroka in the case of grazing propagation. It is given by:

$$n_G = 1 - 0.7 \exp(-h_m/h_G) \quad (V-26)$$

where $h_m = (h_S + h_R)/2$ and $h_G = \lambda/32$.

V.4.1.c. Geometrical weighting factor

For the calculation of the geometrical weighting factor D_k , four cases are considered.

- **Case 1: $i = 0$ and $j = N$** (no diffraction, the direct view from the real source to the real receiver is not blocked by any obstacle)

In this case,

$$D_k = \frac{p_F(S_{r,k'}, R_r)}{p_F(S_r, R_r)} \quad (V-27)$$

with

$$p_F(S, R) = \frac{e^{ik_0 d(S, R)}}{d(S, R)} \quad (V-28)$$

$S_{r,k'}$ is the image source of the source S_r with respect to the ground segment k (see figure V-4).

- **Case 2: $i = 0$ and $j < N$** (i.e. all segments k between the real source and the left-most diffracting edge at P_j)

In this case,

$$D_k = \frac{p_D(S_{r,k'}, P_j, R_r)}{p_D(S_r, P_j, R_r)} \quad (V-29)$$

where p_D is given by equation (V-16).

- **Case 3: $i > 0$ and $j = N$** (i.e. for all segments k between the right-most diffracting edge and the real receiver)

In this case,

$$D_k = \frac{p_D(S_r, P_i, R_{r,k'})}{p_D(S_r, P_i, R_r)} \quad (V-30)$$

$R_{r,k'}$ is the image receiver of the receiver R_r with respect to the ground segment k .

- **Case 4: $i > 0$ and $j < N$** (i.e. between two successive diffracting edges)

In this case,

$$D_k = \frac{p_D(S_r, P_i, P_{j,k'}) p_D(P_{i,k'}, P_j, R_r)}{p_D(S_r, P_i, P_j) p_D(P_i, P_j, R_r)} \quad (V-31)$$

$P_{i,k'}$ and $P_{j,k'}$ are the image points of points P_i and P_j respectively, with respect to the ground segment k .

V.4.1.d. Coherence factor

The coherence factor C_k denotes the loss of coherency due to the fluctuation of the phase difference between direct and reflected sound waves. **This loss of coherency may be due to frequency band integration, uncertainties on source and receiver height and atmospheric turbulence.** The coherence factor is expressed as the product of two coherence factors.

$$C_{coh} = C_a \times C_b \quad (V-32)$$

The coherence factor C_a is linked to the frequency band averaging. It is given by:

$$C_a = \exp\left(-\frac{1}{2}\sigma_\varphi^2\right) \quad (V-33)$$

Where σ_φ is the standard deviation of the fluctuation of the phase difference φ which is calculated with the equation:

$$\varphi = k[d(S', R) - d(S, R)] \approx \frac{2\pi f}{c_0} \frac{2h_S h_R}{D_{SR}} \quad (V-34)$$

with $D_{SR} = d(S, R)$.

σ_φ depends on the standard deviations σ_f , σ_{c_0} , $\sigma_{D_{SR}}$, σ_{h_S} and σ_{h_R} of the quantities f , c_0 , D_{SR} , h_S , and h_R , respectively, by the following relation:

$$\left(\frac{\sigma_\varphi}{\varphi}\right)^2 = \left(\frac{\sigma_f}{f}\right)^2 + \left(\frac{\sigma_{c_0}}{c_0}\right)^2 + \left(\frac{\sigma_{D_{SR}}}{D_{SR}}\right)^2 + \left(\frac{\sigma_{h_S}}{h_S}\right)^2 + \left(\frac{\sigma_{h_R}}{h_R}\right)^2 \quad (V-35)$$

The first term on the right-hand-side is used to account for frequency band integration (the excess attenuation is calculated only at centre frequencies of one-third octave bands; see section 2.2.4). This term is given by:

$$\frac{\sigma_f}{f} = \frac{1}{3} \frac{\Delta f}{f} = \frac{1}{3} \left(2^{B/2} - 2^{-B/2}\right) \quad (V-36)$$

with $B = 1/3$ in the case of one-third octave bands, $B = 1$ in the case of octave bands.

In the second term, a default value of zero is used for σ_{c_0} : this term is neglected, since fluctuations of the sound speed are taken into account separately by coherence factor C_b .

In the third term, a default value of zero is also used for $\sigma_{D_{SR}}$.

In the fourth term and the fifth term, the standard deviations σ_{h_S} and σ_{h_R} are input parameters of the model, which should be specified in combination with the heights h_S , and h_R . The fourth term is taken into account only for the case $i = 0$ (in which the source is the real source); for the

case $i > 0$ (in which the source is a secondary source) the fourth term is neglected. Similarly, the fifth term is taken into account only for the case $j = N$, and neglected for $j < N$. An upper limit of 1 is applied to the fourth term and the fifth term:

$$\text{fourth term} = \min\left(1; \left(\frac{\sigma_{h_s}}{h_s}\right)^2\right) \text{ and fifth term} = \min\left(1; \left(\frac{\sigma_{h_r}}{h_r}\right)^2\right).$$

The coherence factor due to turbulence C_b is given by:

$$C_b = \exp\left(-\frac{3}{8} D_T \gamma_T k_0^2 \rho^{5/3} D_{SR}\right) \quad (V-37)$$

with

$$\gamma_t = \left(\frac{C_T}{T_0}\right)^2 + \frac{22}{3} \left(\frac{C_W}{c_0}\right)^2 \quad (V-38)$$

and

$$\rho = \frac{h_S h_R}{h_S + h_R} \quad (V-39)$$

$C_T=0.364$ is a constant. C_T and C_W are the turbulence structure parameters for temperature and wind speed respectively. In practice, these parameters are not easily accessible, therefore the use of a simplified set of γ_t parameters as direct input data is proposed in the Guidelines for a Competent Use. A typical value for moderate turbulence is $\gamma_t = 5 \cdot 10^{-6}$.

Simplified method	For simplification, a single value for C_{coh} is recommended to be used, implicitly integrating over frequencies, time and space. Details will be provided in the Guidance for the competent use of CNOSSOS-EU.
-------------------	---

V.4.2. Fresnel weighting

V.4.2.a. Basic Fresnel weighting

The Fresnel ellipsoid for the sound propagation from the source S to the receiver R is defined by the set of points P satisfying the equation:

$$d(S, P) + d(P, R) - d(S, R) = \lambda / n_F \quad (V-40)$$

where $d(P, Q)$ is the distance between the points P and Q .

S and R are located at the foci of the ellipsoid, n_F , is the Fresnel parameter.

For the initial calculation of Fresnel weights, $n_F = 8$ is used. A frequency dependent Fresnel parameter is used for the calculation of modified Fresnel weights (see V.4.2.b).

When the sound field is reflected by a plane surface, the image source S' is used instead of S . The Fresnel-ellipse is defined by the intersection between the plane and the Fresnel ellipsoid with foci at the image source point S' and the receiver R as shown in Figure V-5.

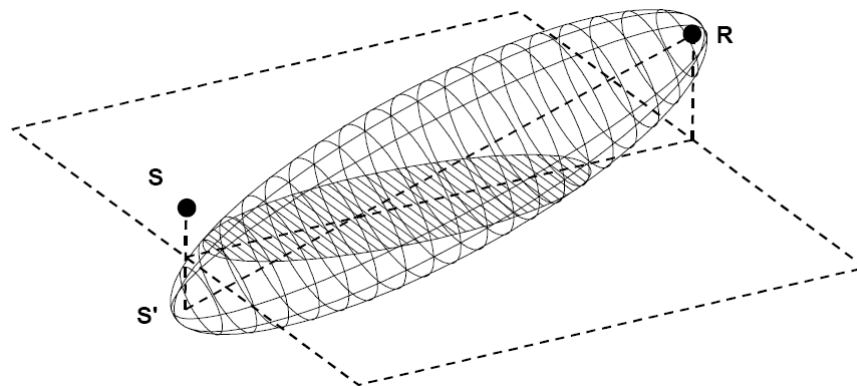

Figure V-5: Definition of Fresnel ellipsoid and Fresnel ellipse [4]

The Fresnel weight of a ground region corresponds to the area of the region included within the Fresnel ellipse, divided by the total surface of the Fresnel ellipsoid. In a two-dimensional propagation model, each ground segment is considered as a strip infinitely long in the third dimension.

Fresnel weights are calculated in local coordinate systems attached to each segment. In the calculation procedures these coordinates are referred to as d (distance along the segment) and h (height relative to the segment). In this local coordinate system dh with the origin at the normal projection of the source S on the plane (figure V-6), the source S coordinates are $(0, h_S)$ and the local receiver R coordinates are (d_{SR}, h_R) .

In this coordinate system, the coordinate of the centre F of the Fresnel ellipse along d -axis is:

$$d_F = \frac{d_{SR}}{2} \left(1 + \frac{h_S^2 - h_R^2}{D^2 - d_{SR}^2} \right) \quad (V-41)$$

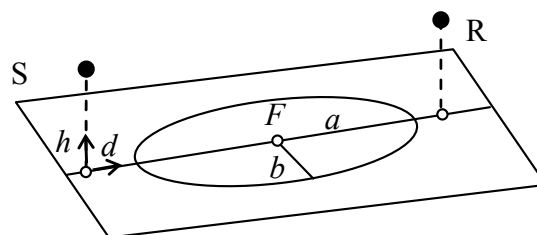

Figure V-6: One-dimensional Fresnel-zone (P_1P_2) in a two-dimensional propagation model

The semi long axis of the Fresnel ellipse, a is given by:

$$a = \frac{1}{2} \sqrt{\frac{D^4 + (D_S^2 - D_R^2)^2 - 2D^2(D_S^2 + D_R^2)}{D^2 - d_{SR}^2}} \quad (V-42)$$

with

$$D = \frac{\lambda}{n_F} + \sqrt{(h_S + h_R)^2 + d_{SR}^2} \quad (V-43)$$

$$D_S^2 = d_F^2 + h_S^2 \quad (V-44)$$

$$D_R^2 = (d_{SR} - d_F)^2 + h_R^2 \quad (V-45)$$

The Fresnel weight $w_{F,k}$ of a ground segment k extending from $d = d_1$ to $d = d_2$ is given by:

$$w_{F,k} = F_w(\xi_2) - F_w(\xi_1) \quad (V-46)$$

where the function F_w is given by:

$$F_w(x) = \begin{cases} 0 & \text{for } x \leq -1 \\ 1 - \frac{1}{\pi} \left(\cos^{-1}(x) - x\sqrt{1-x^2} \right) & \text{for } -1 < x < 1 \\ 1 & \text{for } x \geq 1 \end{cases} \quad (V-47)$$

and the parameter ξ_m (for $m=1, 2$) is given by:

$$\xi_m = \frac{d_m - d_F}{a} \quad (V-48)$$

For the left-end point of the first segment (under the source point), $F_w=0$

For the right-end point of the last segment (under the receiver point), $F_w = 1$

V.4.2.b. Modified Fresnel weighting

In order to improve the accuracy of the Fresnel weighting in the high frequency range, a modified Fresnel weighting is introduced [2]. The expression of the Fresnel weight is similar as equation (V-49) but with modified arguments ξ_m' :

$$w_{F,k} = F_w(\xi_2') - F_w(\xi_1') \quad (V-49)$$

with, for $m=1,2$:

$$\xi_m' = \frac{\xi_m - \xi_C}{1 - \xi_m \xi_C} \quad (V-50)$$

$$\xi_C = \frac{d_C - d_F}{a} \quad (V-51)$$

$$d_C = \alpha(f) d_F + (1 - \alpha(f)) d_{SP} \quad (V-52)$$

$$d_{SP} = d_{SR} \frac{h_S}{h_S + h_R} \quad (V-53)$$

$$\alpha(f) = \left[1 + \left(\frac{f}{f_c} \right)^2 \right]^{-1} \quad (V-54)$$

The Fresnel parameter n_F for the modified Fresnel weight is:

$$n_F = 32 [1 - \exp(-f_c^2/f^2)] \quad (V-55)$$

where f_c is the transition frequency defined hereafter.

V.4.2.c. Transition frequency

The transition frequency f_c is defined as:

$$f_c = \sqrt{f_{\min} f_{\max}} \quad (V-56)$$

Frequencies f_{\min} and f_{\max} verify:

$$\varphi_{\max}(f_{\min}) = \pi/2 \quad (V-57)$$

$$\varphi_{\max}(f_{\max}) = \pi \quad (V-58)$$

where φ_{\max} is the maximum phase difference between direct and reflected sound waves:

$$\varphi_{\max}(f) = \max_k \{ \varphi_k(f) \} \quad (V-59)$$

with

$$\varphi_k(f) = \text{Arg}(Q_k) + k_0 [d(S_k', R) - d(S, R)] \quad (V-60)$$

where $\text{Arg}(Q)$ is the phase shift upon reflection.

More details for the calculation of f_{\min} and f_{\max} can be found in [4].

V.4.3. Transition model

V.4.3.a. Convex segments and coefficients

A typical convex segment is depicted in Figure V-7 in which $h_S < 0$ and $h_R > 0$. The calculation for a convex segment with $h_S > 0$ and $h_R < 0$ would be similar.

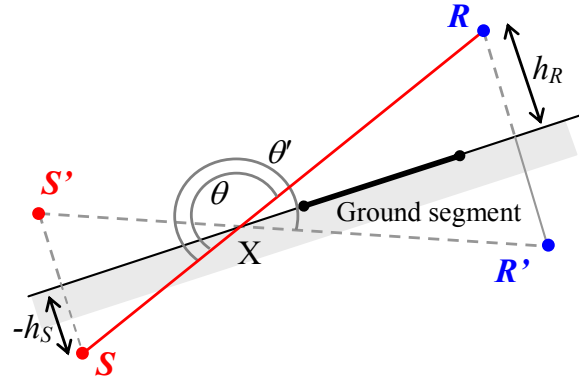

Figure V-7: Geometrical definitions for convex segments

In such a situation, the spherical-wave reflection coefficient Q_k , the geometrical weighting factor D_k , the coherence factor C_k and the Fresnel weight w_k are calculated in a similar way as for concave ground segments, using the equations (V-17) to (V-60) with the two following modifications:

- 1) the source S must be replaced by the image source S' with respect to the ground segment. Consequently, h_S must be replaced by $-h_S$
- 2) the geometrical weighting factor D_k as described in section V.4.1.c must be multiplied by the factor:

$$\frac{p_D(S, X, R')}{p_D(S, X, R)} \quad (V-61)$$

where X is the specular reflection point as depicted in figure V-7, S is the original source before being replaced by S' , and p_D is the diffraction amplitude defined in equation (V-16).

Note that because $\theta = \pi$, the diffraction amplitude $p_D(S, X, R) = \frac{1}{2} p_F(S, R)$ with p_F defined in equation (V-28).

V.4.3.b. Convex ground attenuation

For the calculation of the convex ground attenuation $\Delta L_{Gt}(P_i, P_j)$, it is first necessary to determine the “highest” diffracting edge P_k below the line SR . This point P_k corresponds to the smallest path length difference as defined by equation (V-7).

Then the convex ground attenuation $\Delta L_{Gt}(P_i, P_j)$ is calculated by:

$$\Delta L_{Gt} = \chi \Delta L_1 + (1 - \chi) \Delta L_2 \quad (V-62)$$

with
$$\Delta L_1 = \Delta L_D(S, P_k, R) + \Delta L_{Gc}(P_i, P_k) + \Delta L_{Gc}(P_k, P_j) \quad (V-63)$$

and
$$\Delta L_2 = \Delta L_{Gc}(P_i, P_j) \quad (V-64)$$

where ΔL_D is the diffraction attenuation defined in section V.3, and ΔL_{Gc} is the ground attenuation for concave segments as defined in section V.4.1.a, taking into account the modifications specified in section V.4.3.a.

The factor χ in equation (V-62) is given by:

$$\chi = \chi_2 + (1 - \chi_1)(1 - \chi_2) \quad (V-65)$$

where χ_1 is given by:

$$\chi_1 = \begin{cases} 1 - \exp(-1/\tau_1^2) & \text{for } \tau_1 > 0 \\ 1 & \text{for } \tau_1 \leq 0 \end{cases} \quad (V-66)$$

with
$$\tau_1 = \frac{\delta_{spec,avg} - \delta_{dif}}{\lambda/8} \quad (V-67)$$

and where χ_2 is given by:

$$\chi_2 = \begin{cases} 1 - \exp(-1/\tau_2^2) & \text{for } \tau_2 > 0 \\ 1 & \text{for } \tau_2 \leq 0 \end{cases} \quad (V-68)$$

with
$$\tau_2 = \frac{\delta_{dif}}{\lambda/64} \quad (V-69)$$

The quantity δ_{dif} is defined as the path length difference of the diffracted path $S-P_k-R$ and the direct path $S-R$ as defined by equation (V-7).

The quantity $\delta_{spec,avg}$ is defined as:

$$\delta_{spec,avg} = \frac{\sum_{k=i}^{j-1} w_k \delta_{spec,k}}{\sum_{k=i}^{j-1} w_k} \quad (V-70)$$

For each ground segment k , $\delta_{spec,k}$ is defined as:

$$\delta_{spec,k} = d(S_k', R) - d(S, R) \quad (V-71)$$

where S_k' is the image of source with respect to the ground segment k .

V.5. Atmospheric refraction

V.5.1. Sound speed profile

The effect of atmospheric refraction is based on the assumption of a linear vertical profile of the effective sound speed:

$$c(z) = c_0 \left(1 + \frac{z}{R_c}\right) \quad (V-72)$$

where R_c is a constant, z is the vertical coordinate and c_0 is the sound speed defined as a function of the absolute temperature T (in Kelvin)

$$c_0 = c_{ref} \sqrt{\tau / \tau_{ref}} \quad (V-73)$$

with $c_{ref} = 331$ m/s and $\tau_{ref} = 273$ K

Under such a profile, ray paths are circular with a radius of curvature approximately equal to $|R_c|$. However, atmospheric refraction is modelled more efficiently by using the curved ground analogy.

In practice, the value of R_c is linked to meteorological parameters through a more realistic approximation of the sound speed profile, known as the lin-log profile. Details are provided in Annex V-A.

V.5.2. Curved ground analogy

In this analogy, a transformation of coordinate, called conformal mapping, is applied in order to convert circular ray paths into straight paths. In this way, the calculation scheme as described in the previous sections for straight ray paths can be applied to the transformed system.

The conformal mapping in the complex plane consists in the transformation of the complex coordinate $w = x + iz$ ($i = \sqrt{-1}$) into $w' = x' + iz'$, with:

$$w' = \frac{C(w - w_0)}{C + (w - w_0)} \quad (V-74)$$

With

$$w_0 = \frac{x_0 + x_N}{2} + i \frac{z_0 + H_S + z_N + H_R}{2} \quad (V-75)$$

$$C = i C_0 \quad (V-76)$$

$$C_0 = 2 \times \left(\frac{H_S + H_R}{2} + R_c \right) \quad (V-77)$$

By applying this transformation to the two-dimensional wave equation in the xz plane with varying sound speed $c(z)$ as defined in equation (V-72), a transformed wave equation in the $x'z'$

plane is obtained. In this new wave equation, sound speed can be approximated as a constant $c(z) \approx c_0$ when the source-receiver distance $d(S,R)$ is such that $d(S,R) < 0.2 |R_c|$.

In other words, the curve ground analogy should only be applied in cases where $|R_c|$ is larger than five times the source-receiver distance. This condition usually holds for typical road and railway traffic noise predictions, with moderate sound speed gradients (i.e. $1/R_c < 0.1 \text{ s}^{-1}$) and propagation distances up to 1000 m.

Equations (V-74) to (V-77) lead to:

$$x' = \frac{C_0^2 x''}{x''^2 + (C_0 + z'')^2} \quad (V-78)$$

$$z' = \frac{C_0 (x''^2 + z''^2 + z'' C_0)}{x''^2 + (C_0 + z'')^2} \quad (V-79)$$

with
$$x'' = x - \frac{x_0 + x_N}{2} \quad (V-80)$$

and
$$z'' = z - \frac{z_0 + H_S + z_N + H_R}{2} \quad (V-81)$$

V.6. Scattering by atmospheric turbulence

The effect of scattering of sound waves by atmospheric turbulence is introduced by the addition of a turbulent scattering term, ΔL_{scat} , to the excess attenuation. This term is defined by:

$$\Delta L_{scat} = 25 + 10 \lg \gamma_t + 3 \lg \frac{f}{1000} + 10 \lg \frac{d}{100} \quad (V-82)$$

where d is the horizontal distance between the source and the receiver, and γ_t is a parameter used to describe the turbulence strength. γ_t is defined in section V.4.1.d in equation (V-38).

References

- [1] R. Nota et al., *Engineering method for road traffic and railway noise after validation and fine-tuning*, EU-FP5 project "HARMONOISE" deliverable report n°D18 (HAR32TR-040922-DGMR20), DGMR, 2005.
- [2] B. Plovsing, J. Kragh, *Nord2000. Comprehensive Outdoor Sound Propagation Model. Part 1: Propagation in an Atmosphere without Significant Refraction*, Report for the Nordic Group AV 1849/00, Delta, 2001.
- [3] D.van Maercke, J.Defrance, *Development of an Analytical Model for Outdoor Sound Propagation Within the Harmonoise, Acta Acustica united with Acustica*, Vol. **93(2)**, p. 201-212, 2007.
- [4] E. Salomons, D. van Maercke, J. Defrance, F. De Roo, *The Harmonoise sound propagation model*, to be published in *Acta Acustica united with Acustica*.

- [5] E. Salomons, D. Heimann, *Description of the Reference model*, EU-FP5 project “HARMONOISE” deliverable report n°D16 (HAR29TR-041118-TNO10), TNO, 2004.
- [6] ISO 9613-1:1993(E), "*Acoustics - Attenuation of sound during propagation outdoors- Part 1: Calculation of the absorption of sound by the atmosphere*", International Organization for Standardization, Geneva, 1993.
- [7] J. Deygout, Multiple knife-edge diffraction by microwaves, *IEEE Trans. Antennas and Propagation* **14**, p. 480–489, 1966.
- [8] C. F. Chien, W. W. Soroka, A note on the calculation of sound propagation along an impedance boundary, *Journal of Sound and Vibration* **69**, p. 340-343, 1980.
- [9] D. van Maercke, *Specifications for GIS-NOISE databases*, EU-FP6 project “IMAGINE” deliverable report n°D4 (IMA10-TR250506-CSTB05), CSTB, 2007.

APPENDIX V-A - Linearization of logarithmic sound speed profiles

Starting from a lin-log profile

$$c(z) = c_0 + A_m \cdot z + B_m \ln\left(1 + \frac{z}{z_0}\right)$$

We calculate the equivalent ray curvature by :

$$\frac{1}{R} = \frac{1}{R_A} + \frac{1}{R_B}$$

Note : because we need to handle the case $1/R = 0$ or equivalently $R = \infty$ it is recommendable to calculate the quantity $1/R$ directly without explicit calculation of R .

The linear part of the gradient is calculated as :

$$\frac{1}{R_A} = \frac{A_m}{c_0}$$

The logarithmic part of the gradient is calculated as :

- if $B_m \leq 0$:

$$\frac{1}{R_B} = \frac{B_m}{h_M \cdot c_0}$$

- if $B_m > 0$:

$$\text{if } A < 0 : \frac{1}{R_B} = \frac{\sqrt{B^2 - AC} - B}{C}$$

$$\text{if } A \geq 0 : \frac{1}{R_B} = 0$$

where :

$$k = \sqrt{\frac{B}{2\pi c_0}}$$

$$\gamma = \frac{1 + 4k^2}{1 - 4k^2}$$

$$\text{tg}\theta = \frac{h_R - h_S}{d_{SR}}$$

$$h_M = \frac{h_S + h_R}{2}$$

$$d = \sqrt{d_{SR}^2 + (h_S - h_R)^2}$$

and

$$A = 1 + tg^2\theta - \gamma^2$$
$$B = h_M(1 + tg^2\theta)$$
$$C = h_M^2(1 + tg^2\theta) + (d/2)^2$$

CHAPTER VI. AIRCRAFT NOISE PREDICTION

VI.1. The component of CNOSSOS-EU for aircraft noise

European Commission in order to match the objectives of the END and in the context of the preparation of common noise assessment methods in EU (CNOSSOS-EU) tries to take benefit from the best existing noise assessment methods and knowledge worldwide. For this purpose, the European Commission's Joint Research Centre (JRC) in liaison with the Directorate General for the Environment (DG ENV) and European Environment Agency (EEA) organised on 19-20 January 2010 in Brussels an ad hoc workshop on "*Aircraft Noise Prediction*" with the aim to discuss among EU experts about the aircraft noise module of CNOSSOS-EU.

This workshop was a follow-up of the Workshop on the "*Selection of common noise assessment methods in EU*" previously organised by JRC, DG ENV and the EEA which took place on 8-9 September 2009 in Brussels. Among the recommendations of that Workshop, was to take as basis for the aircraft module of the CNOSSOS-EU method the Document 29 (3rd Edition) of the European Civil Aviation Conference (ECAC). Some potential improvements were identified and further discussed during the workshop on "*Aircraft Noise Prediction*" in January 2010. These were mainly concerned with considering the use of some features of the German AzB method for improving the ECAC Doc.29, 3rd Edition method.

During the Workshop's discussions, it was recognised that aircraft noise modelling is specific compared to the other three noise sources (road traffic, railway traffic and industrial). There is a long-standing experience in aircraft noise assessment, and prediction methods together with associated performance databases are worked out and defined at international levels. However, it was recognised that for some of the issues discussed, there is still room for improvements in the existing methods and procedures.

The representatives of the European Commission and the aircraft noise experts participated in the Workshop recognised that worldwide resources to develop and maintain aircraft noise modelling tools are limited and as such, it is critical to increase synergies among the stakeholders affected and maximise commonality of both, the methodology and the input data.

VI.2. Recommendations

During the workshop on "*Aircraft Noise Prediction*", the discussions focused on some specific issues which had to be elucidated for considering ECAC Doc.29 3rd Edition in relation to the requirements of the END. The technical issues discussed and the specific recommendations made are briefly summarised below.

Specific issues and recommendations regarding the aircraft noise propagation:

- 1/3 octave band calculations for aircraft noise propagation

- It should be explained in the next draft of CNOSSOS-EU why the ECAC Doc29 method is a full 1/3 octave band method though it is expressed mainly through overall integrated A-weighted levels.

➤ Adaptation of the ANP database to local meteorological conditions

- To allow the use of local specific meteorological conditions for calculating aircraft flight performance.
- To use the text of Annex D of ECAC Doc29, 3rd Ed., Vol.2 as part of CNOSSOS-EU to account for, where necessary, the effect of local atmospheric conditions on the changing of the propagation (air absorption).
- To explain in the Guidance for the competence use of CNOSSOS-EU how to correct the average year conditions with the specific meteorological conditions.

➤ The effect of moving the receiver point to 4 m high (at the moment, ANP data are recorded at 1.2 m high)

- 4.0 m is the required position in END for all four noise sources (road traffic, railway traffic, aircraft and industry)
- The existing evidence shows that in general the difference between 1.2 m and 4.0 m is well below 1 dB for soft grounds and angles of incidence above 15°. Over reflecting ground and for lower angles of incidence, there is no clear evaluation at the moment of the difference.
- Even if the difference is small, the number of affected people may vary significantly (possibly tens of thousands of people). Thus, any correction value or methodology chosen will need a strong evidence base.
- It is, therefore, recommended to state in CNOSSOS-EU that the height of the assessment point may have an influence but for the time being and in the transition time a default correction of zero will be accepted and existing NPD data at 1.2 m will be accepted (see above).

➤ Consideration of sound reflections on the ground

- The existing evidence shows that, in general, a difference exists between different ground types because of the change in the absorption factor, and measurements confirm that it can be up to 2-3 dB in the overall (A) weighted level.
- It is also recognised that, at the moment, more evidence is needed to propose a correction for ground reflection and that correction is suggested to be avoided because of: (a) the increase in the calculation times; (b) the difficulty to gather input values on ground type and (c) the impact that a fragmented noise contour may have when communicated to the public.
- It is recommended to state in CNOSSOS-EU that, the ground absorption factor may have an influence. It was suggested this issue to be further investigated and other alternative approaches to be possibly considered as well before any methodology is considered for implementation.

➤ Consideration of screening effects and reflections on vertical obstacles

- It is recognised that the presence of vertical reflecting objects close to the receiver may have an effect on noise which sometimes can be positive or negative.
- The inclusion of screening/reflections on obstacles would result in much longer calculation times (and is thus impractical to consider) due to a much finer resolution grid and more input data about these obstacles, which is not available in some EU MS. Therefore, it is recommended not to consider these obstacles' screening and reflection effects in CNOSSOS-EU.

➤ The improvements linked to the use of radar tracks (or inaccuracies due to the absence of radar track profiles)

- The horizontal track dispersion should be addressed in CNOSSOS-EU.
- The technique to be used to separate and obtain the sub-tracks will be defined in CNOSSOS-EU, specifying that the radar tracks have primarily to be used, when available.
- There is some knowledge on the inaccuracy introduced by the assumptions on the standard tracks dispersion.
- Appropriate guidance will be provided by experts of the AIRMOD group on the use of sub-tracks to be introduced in the CNOSSOS-EU together with the associated accuracy.

➤ The comparison between ECAC Doc. 29, 3rd Edition and the German method AzB

AzB uses a more detailed acoustical algorithm (spectral calculation, non-generalised directivity) which will give modelling flexibility when its accompanying aircraft noise source database is populated with the relevant information. ECAC Doc.29 provides much more flexibility in generating individual (aircraft-specific) flight paths. The AzB is primarily designed to produce historical noise contours around German airports (using noise and performance data for groups/categories of aircraft), whereas ECAC Doc.29 and the large ANP database provides more functionality, e.g. for noise mitigation studies or studies on the effect of noise abatement flight procedures and operating restrictions (c.f. Directive 2002/30/EC). AzB additionally covers military and general aviation as well as helicopters and parts of ground operations. However, it only considers a limited number of groups of aircraft, whereas ECAC Doc. 29 contains a large number of individual airframe/engine combinations, via its associated ANP database. In principle, both models are easily extensible (AzB with respect to operational aspects, ECAC Doc.29 with respect to other fields of application).

Specific issues and recommendations regarding the *aircraft noise emission database*:

➤ Validation of aircraft noise predictions

- EC is interested in assessing noise in residential areas and supports the definition of accurate guidelines that can allow for validation of predictions in such areas. Such validation is however dependent on an agreed process for the collection and processing of noise measurements.
- More comparisons between measurements and calculations should be produced and published, provided a comparison process can be agreed.
- A common validation procedure of aircraft noise calculations should be established.

➤ The integration of light aircrafts and helicopters

- It should be checked whether the light aircraft in DIN 45684 can complement the ANP with EU types of light aircraft.
- For other missing aircraft types, substitution rules have to be provided in the CNOSSOS-EU guidelines.
- As was shown by past EU projects, a separate model is required for helicopter noise based on completely different asymmetric principles. There is, at the moment, an alternative method (HELENA) with a limited database which is under development, hence, not yet mature to be taken on board by CNOSSOS-EU.
- Provisionally, helicopters can be included as symmetric sources (like fixed wing aircraft) although this will introduce an error which might be significant depending on the specific situation. EU MS should be consulted on this issue.

➤ The consideration of ground operations

- From a technical point of view, noise from ground operations could be treated as industrial noise.
- During the revision of the END, the EC will consult the EU MS to discuss whether and how ground operations should be included in CNOSSOS-EU.
- Taxiing should be excluded from ground operations for strategic noise mapping since it is of marginal effect, but could be included as part of the aircraft ground operations for assessing specific effectiveness of action plans around airports.

The set of generic recommendations made by the aircraft noise experts during the aforementioned workshop are the following:

Generic recommendations regarding the *aircraft prediction methodology*:

- ECAC Doc. 29, 3rd Edition should be used as the basis when discussing the aircraft module of CNOSSOS-EU.
- ECAC Doc. 29, 3rd Edition will be adopted as the common method for strategic noise maps for aircraft noise in EU (i.e. the aircraft module of CNOSSOS-EU), and a process will be put in place to consider proposed modifications/amendments of ECAC Doc. 29 3rd Ed.
- European Commission will take ownership and oversight of any process for maintaining, developing (including the software implementation) and disseminating the CNOSSOS-EU. It is strongly desirable to reach agreement at international level which could best be achieved through the ICAO environmental committee, CAEP, and involve all relevant European stakeholders (DG ENV, DG TREN, DG JRC, EU MS, EASA, EEA) associated to the implementation of the END.
- A provision to permit modellers to use the updated versions of the CNOSSOS-EU including the aircraft noise module should be proposed if published in between any reviews of the END (e.g. Adaptation to Technical Progress process to be included in the review of the END).

Generic **recommendations regarding the *aircraft noise and performance database*:**

- The ICAO Aircraft Noise and Performance (ANP) Database is currently the best candidate for achieving a global consensus on an aircraft noise and performance input database.
- However, standardisation on a transparent, comprehensive and accurate source of input data would result in significant benefits in the quality of airport noise contour modelling.
- Standardisation should ensure an exact same aircraft configuration and operation would produce consistent predicted noise impacts across all EU Member States, unless local adjustments are justified.
- A robust validation process of ANP data should be formalized at the ICAO level. In particular, significant improvements are required in the approval process for aircraft noise and performance data to ensure high quality model input, and to avoid potential discrimination between aircraft manufacturers.
- Due to the international nature of the aviation industry, all data should be reviewed and approved against an agreed set of international requirements. This could build on existing European (EASA) - US (FAA) approval processes, such as that for aircraft

noise certification, in order to benefit from significant synergies.

- Some specific types of aircraft should be included. Ground operations should also be included, presumably by using the “industrial noise” module of CNOSSOS-EU.
- An international agreement could best be achieved through the ICAO environmental committee, CAEP, and would involve all relevant stakeholders including the DG ENV, DG TREN, DG JRC, EASA and EU Member States.
- Transition issues for EU Member States should also be taken into account in moving towards a common noise modelling methodology/database. As such, proposed future plans should be communicated as soon as possible.

Generic recommendations regarding the future of ECAC doc. 29, 3rd Ed., Vol. 3:

- Guidelines should be given on how experimental data, collected at a particular airport, can be used to build, complete and validate the source database (ANP) included with the method.

N.B.: Chapter VI at this stage includes only the draft recommendations made during the Workshop on “*Aircraft noise prediction*” took place on 19-20 January 2010 in Brussels. The drafting of chapter VI will be done after the minutes of this Workshop will be finalized.

CHAPTER VII. GUIDANCE ON THE COMPETENT USE OF CNOSSOS-EU

VII.1. Scope, aims and objectives of the guidance

In the context of the 1st round of noise mapping the END, the EU MS had available an array of differing documents which could be called upon to support their strategic noise mapping activities. These included, but were not limited to, the following key references:

- WG-AEN, Good Practice Guide for Strategic Noise Mapping and the Production of Associated Data on Noise Exposure, Version 2 [1];
- WG-AEN, Presenting Noise Mapping Information to the Public, March 2008 [2];
- Wolfel et al., Adaptation and revision of the interim noise computation methods for the purpose of strategic noise mapping [3];
- OJEU, Commission Recommendation 2003/613/EC [4];
- Hepworth Acoustics, NANR 93 [5];
- Hepworth Acoustics, NANR 208 [6];
- EC, ENDRM 2007 [7];
- IMAGINE, WP1 Final report [8];
- NoMEPorts, Good Practice Guide [9];
- DIN 45687 [10];
- Various national guidance documents, such as Ireland [11].

It is not known definitively to what extent any, or all, of these guidance documents were utilised during the strategic noise mapping projects during 2007, however, hearsay evidence suggests that aside from the WG-AEN GPGv2 knowledge of, and subsequent use of, the other reference documents above was inconsistent. Furthermore, as all of the knowledge and guidance on best practice was merely informative, and non-mandatory, there resulted in a wide range of “acceptable” approaches to the strategic noise mapping in 2007. As a result, the information reported to the EC, and subsequently analysed by the EEA [12], presents an array of apparent inconsistencies and uncertainties when comparing results between MS [13].

The fractured and disparate nature of the guidance infrastructure around the first round strategic noise mapping naturally lead to an array of approaches, and the introduction of uncertainty into the process when considering equivalence and comparability. In the light of this experience, it was decided that the development of the CNOSSOS-EU methods would be accompanied by the development of a unified set of guidelines on the practical application of the CNOSSOS-EU methods within the two identified “fit-for-purpose” applications.

The scope of the Guidance has developed alongside the CNOSSOS-EU methods. The requirement for unified Guidance was expressed during extensive discussions in practically all the CNOSSOS-EU related Workshops and ad hoc meetings took place in 2009-2010. These discussions led to a proposed concept for the Guidance aimed at support the end users in the application of the proposed CNOSSOS-EU methods. Whilst the technical descriptions of the CNOSSOS-EU methods are to focus on what the methods entail, the Guidance will come

alongside the technical descriptions of the methods and will focus on how the methods are to be applied in practice.

The proposed approach of establishing a common framework for implementation needs to recognise and accommodate local and regional variations, be flexible in its approach, whilst providing a means to enable EC, EU MS, Competent Authorities, guiding experts and stakeholders to understand the sources and extents of uncertainties within the process. The approach should support and encourage sharing of data, experience and best practice between stakeholders; support the aims of the INSPIRE Directive; and assist adjacent EU MS and Competent Authorities to meet their obligations. It is proposed to set out a logical staged approach to undertaking strategic noise mapping under the Directive, and within each stage discuss specific challenges, solutions, uncertainties, interpretations and guidance as appropriate.

At present, it is proposed to develop the Guidance as an interactive web based tool which links together the Guidance with the specific aspects of the technical description. It is considered that this presents the opportunity to develop a community of users able to share challenges, solutions and best practice, whilst enabling the Guidance to develop in tandem with experience of applying the CNOSSOS-EU methods within real world situations.

The process outlined above has led to a description of the scope, aims and objectives of the Guidance for the CNOSSOS-EU methods. The primary aim is to bring together the key aspects of best practice currently set out within an array of documents and reports, as discussed above. It is also important to consider that the experience of undertaking the strategic noise mapping under the first round of the Directive in 2007, along with subsequent technical and policy development, has led to a secondary aim that Guidance is to be developed and extended beyond the previously available documents. Some of these aspects, which are currently under consideration include:

- Data capture methods:
 - How to capture specific noise related data, such as train emissions, vehicle noise, rail/wheel roughness, road surface data etc;
- GPGv2 Toolkits:
 - Updated and expanded to deal with CNOSSOS-EU, and what is to be done when data is available, or not;
- Data schema design:
 - Inputs and outputs for CNOSSOS-EU;
 - Data specification tables and schema diagram ;
 - An INSPIRE compliant, open and extensible standard;
 - Includes rules and guidance on how additional objects & attributes may be added to the schema; and
 - Provides a common data format which empowers interfacing with data providers, other data owners and cross border project liaison.
- Use of noise mapping software:
 - User settings and calculation processing;
 - Control of uncertainty as per DIN 45687;
 - Receptor points for population assessment;

- Grids only for graphics; and
 - Guidance on grid resolution for final mapping scale.
- Post processing:
- Interpolation of grids for “missing” points or contours, presentation of maps;
 - Population exposure assessment ;
 - Reporting to EC (ENDRM); and
 - Presentation to the public and stakeholders.

As mentioned previously the concept, scope and specifics of the Guidance on CNOSSOS-EU outlined here are an insight into the current status of the design process, rather than a definitive specification. As such, there may well be changes when the Guidance is compared to these ideas presented here. It may be the case that some aspects are moved to other documents, some are no longer considered relevant, or that others may be added to the Guidance which are not discussed above. In any event, the wider community of experts in environmental noise and mostly the representatives of the EU MS are encouraged to come forward with suggestions, proposals or ideas to help promote the quality and use of the Guidance in close association with the CNOSSOS-EU methods.

The concept and content of the Guidance on the competent use of CNOSSOS-EU will be further and formally discussed and finalised along with the CNOSSOS-EU methodological framework together with the EU MS starting from the Noise Regulatory Committee meeting on 11 June 2010 in Brussels.

References

- [1] European Commission Working Group Assessment of Exposure to Noise (WG-AEN), Position Paper, Good Practice Guide for Strategic Noise Mapping and the Production of Associated Data on Noise Exposure, Version 2, 13th August 2007.
- [2] European Commission Working Group Assessment of Exposure to Noise (WG-AEN), Position Paper, Presenting Noise Mapping Information to the Public, March 2008.
- [3] EC Contract B4-3040/2001/329750/MAR/C1 “Adaptation and revision of the interim noise computation methods for the purpose of strategic noise mapping”.
- [4] Official Journal of the European Union (OJEU) 6 August 2003, Commission Recommendation 2003/613/EC.
- [5] Hepworth Acoustics, NANR 93: WG-AEN’s Good Practice Guide and the Implications for Acoustic Accuracy, May 2005. Research report for Defra.
- [6] Hepworth Acoustics, NANR 208: Noise Modelling, Final Report, May 2007. Research report for Defra.
- [7] European Commission, Reporting Mechanism proposed for reporting under the Environmental Noise Directive 2002/49/EC - Handbook (including Data Specifications), October 2007.
- [8] IMAGINE - WP1 Final report, Guidelines and good practice on strategic noise mapping, Deliverable 8 of the IMAGINE project, February 2007.
- [9] Good Practice Guide on Port Area Noise Mapping and Management, NoMEPorts, April 2008.
- [10] DIN 45687 Acoustics - Software products for the calculation of the sound propagation outdoors - Quality requirements and test conditions.

- [11] Environmental Protection Agency of Ireland, EPA Guidance Note for Strategic Noise Mapping.
- [12] Nugent, C., Overview of noise exposure resulting from Strategic Noise Mapping, Proceedings of Euronoise 2009, 26-28 October 2009, Edinburgh.
- [13] Van den Berg, M. and Licitra, G., EU-Noise Maps: analysis of submitted data and comments, Proceedings of Euronoise 2009, 26-28 October 2009, Edinburgh.